

# MADISON COUNTY PLANNING BOARD

P.O. Box 278 • Virginia City, Montana 59755 • Phone (406) 843-5250 • Fax (406) 843-5229

---

Madison County is updating two planning documents, the Growth Policy and Subdivision Regulations. Both DRAFT documents are available at [www.madisoncountymt.gov](http://www.madisoncountymt.gov); please be aware that the draft documents are still being edited for formatting and all references are undergoing verification.

The Growth Policy is similar to a community master plan and includes a snapshot of Madison County today, amongst other topics that are required by State statute, Montana Code Annotated Title 76 Part 6. This long-range plan is NOT a regulatory document, meaning that Madison County cannot approve or deny land use development proposals based solely on compliance with the Growth Policy. But without this plan in place, the County cannot impose any land use regulations that are not considered, discussed, or contemplated within the Growth Policy. The Growth Policy functions similarly to a foundation on which you build your house (land use regulations). This plan includes goals, objectives, and an action plan that will guide community development within Madison County through 2030.

The Madison County Subdivision Regulations are a regulatory document that govern all subdivision development proposals within Madison County. The majority of these regulations are prescribed by State statute, Montana Code Annotated Title 76 Part 5, although the County has some freedom to customize the design standards for subdivision development. It's important to note that when reviewing subdivision development proposals, State statute (AKA land use law) requires that all efforts to mitigate development impacts must be exhausted to legally deny a subdivision proposal. This is important to understand because it's not as simple as just "stopping subdivision development". Madison County's goal is to work within the legal framework set forth in Montana Code Annotated, while supporting responsible growth and respecting private property rights.

It is Madison County's intent to review and refine the Subdivision Regulations every two years, following the legislative session. Although we will be adopting updated Subdivision Regulations in early 2025, we anticipate an almost immediate subsequent update in the summer of 2025, after the general session has concluded. That first update will include any necessary statutory compliance amendments and refinement to the watercourse/waterbody setbacks design standards.

The Madison County Planning Board previously discussed the update of the aforementioned planning documents and proposed working through adoption of the Subdivision Regulations first, followed by the Growth Policy. However, because the Subdivision Regulations contain information from the Growth Policy, we have decided to first work through the Growth Policy so that both documents are in alignment. We are anticipating the following public meetings, hosted by the Planning Board, to review these documents:

- Tuesday, January 7, 2025 – Subdivision Regulations WORK SESSION  
(4 pm in the Admin Building Public Meeting Room in Virginia City)
- Monday, January 27, 2025 – Growth Policy Public Hearing  
(6 pm in the Admin Building Public Meeting Room in Virginia City)
- Monday, February 24, 2025 – Subdivision Regulations Public Hearing  
(6 pm in the Admin Building Public Meeting Room in Virginia City)

# MADISON COUNTY PLANNING BOARD

P.O. Box 278 • Virginia City, Montana 59755 • Phone (406) 843-5250 • Fax (406) 843-5229

---

The “work session” will be an informal meeting in which the public and Planning Board can verbally work through questions and concerns regarding Subdivision Regulations content and make any necessary amendments to the draft; no voting or recommendations will result from this work session. The public hearings work similarly, except that at the conclusion of each public hearing, the Madison County Planning Board will make a recommendation for adoption to the Madison County Board of Commissioners. The Growth Policy and the Subdivision Regulations will also be reviewed at a public hearing hosted by the Madison County Board of Commissioners at dates yet to be determined. All public hearings will be publicly noticed.

For more information, please reach out to the Madison County Planning Department at [planning@madisoncountymt.gov](mailto:planning@madisoncountymt.gov) or (406)843-5250.



# **MADISON COUNTY SUBDIVISION REGULATIONS**

Adopted \_\_\_\_\_ 2025  
Ordinance No. \_\_\_\_\_-2025

**As Amended and Adopted by:  
Madison County Board of Commissioners on [INSERT DATE]**

**Prepared to comply with the  
Montana Subdivision and Platting Act, as set forth in Title 76, Chapter 3,  
Montana Code Annotated (MCA)**

**DRAFT**

**The Madison County Subdivision Regulations Resolution of Adoption is kept on file at the Office of the Madison County Board of Commissioners and the Office of the Madison County Clerk and Recorder.**

**Copies of the Resolutions will be provided upon request.**

# TABLE OF CONTENTS

---

<b>DEFINITIONS</b> .....	<b>8</b>
<b>I. GENERAL PROVISIONS</b> .....	<b>21</b>
I-A. Title.....	21
I-B. Authority.....	21
I-C. Purpose.....	21
I-D. Jurisdiction.....	21
I-E. Severability.....	22
I-F. Public Hearing and Notice.....	22
I-G. Construction Timing.....	23
I-H. Transfer of Title.....	23
I-I. Permission to Enter.....	23
I-J. Variances.....	24
I-J-1. Variances Authorized.....	24
I-J-2. Variances from Floodway Provisions Not Authorized.....	24
I-J-3. Variance Criteria.....	24
I-J-4. Procedure.....	24
I-J-5. Conditions.....	25
I-J-6. Statement of Facts.....	25
I-K. Amendment of Regulations.....	25
I-L. Administration.....	25
I-L-1. Enforcement.....	25
I-L-2. Violation and Penalties.....	25
I-L-3. Schedule of Fees.....	25
I-L-4. Appeals.....	26
I-M. Roles of Planning Board and Planner.....	23
I-N. Compliance.....	24
<b>II. General Procedures</b> .....	<b>28</b>
II-A. Preliminary Plats.....	28
II-A-1. Pre-application Process.....	28
II-A-2. Subdivision Application and Preliminary Plat Submittal.....	29
II-A-3. Review Process.....	31
II-A-4. Amended Applications.....	33
II-A-5. Amending Approved Preliminary Plats Before Final Plat Approval.....	34
II-A-6. Extension of Preliminary Plat Approval Period.....	35
II-B. Final Plats.....	36
II-B-1. Final Plat Contents.....	36

II-B-2. Final Plat Initial Review.....	36
II-B-3. Subdivision Improvements Agreement: Guaranty.....	37
II-B-4. Final Plat Approval.....	39
II-B-5. Final Plat Filing.....	39
II-B-6. Amending Filed Plats.....	39
<b>III. REVIEW AND APPROVAL PROCEDURES FOR MINOR SUBDIVISIONS.....</b>	<b>42</b>
III-A. First Minor Subdivisions.....	42
III-A-1. First Minor Subdivision Review.....	42
III-A-2. First Minor Subdivision Application and Preliminary Plat Submittal.....	42
III-A-3. First Minor Subdivision Exceptions.....	42
III-A-4. First Minor Subdivision Review Process.....	42
III-A-5. First Minor Planning Board Recommendation and Governing Body Consideration and Decision.....	44
III-A-6. Amended Applications Prior to Governing Body Decision.....	48
III-A-7. Subdivider’s Preference for Mitigation.....	48
III-A-8. First Minor Subdivision Final Plat.....	48
III-B. Subsequent Minor Subdivisions.....	48
III-C. Administrative Minor Subdivisions.....	48
III-C-1. Criteria to Be Met.....	48
III-C-2. Exemptions for Administrative Minor Subdivision.....	49
III-C-3. Planner Review.....	49
III-C-4. Objections to Planner Review.....	49
III-C-5. Other Requirements.....	49
<b>IV. REVIEW AND APPROVAL PROCEDURES FOR MAJOR SUBDIVISIONS.....</b>	<b>50</b>
IV-A. Review and Approval Procedures for Major Subdivisions.....	50
IV-A-2. Subdivision Application and Preliminary Plat Submittal.....	51
IV-A-3. Phased Subdivision and Preliminary Plat Submittals.....	51
IV-A-4. Time Period for Approval, Conditional Approval, or Denial.....	52
IV-A-5. Amended Applications Prior to Public Hearing.....	52
IV-A-6. Planning Board Recommendation and Governing Body Consideration and Decision.....	53
IV-A-7. Subdivider’s Preference for Mitigation.....	57
IV-A-8. Amended Applications Following the Public Hearing.....	57
IV-A-9. Governing Body Meeting – Consideration of New Information.....	57
IV-A-10. Subsequent Public Hearing.....	58
IV-B. Major Final Plats.....	58
<b>V. EXPEDITED SUBDIVISION REVIEW.....</b>	<b>59</b>
V-A. Requirements.....	59

V-B. Exemptions.....	59
V-C. Subdivision Application Review.....	59
V-D. Governing Body Review.....	60
V-E. Extensions.....	60
V-F. Unlawful Restrictions.....	61
V-G. Applicable MSPA Requirements.....	61
<b>VI. DESIGN AND IMPROVEMENT STANDARDS.....</b>	<b>62</b>
VI-A. Conformance with Regulations.....	62
VI-B. Natural Environment.....	62
VI-C. Lands Unsuitable for Subdivision.....	62
VI-D. Floodplain Provisions.....	62
VI-E. Improvement Design.....	63
VI-F. Lots.....	63
VI-G. Blocks.....	64
VI-H. Streets and Roads.....	64
VI-I. Postal Service.....	70
VI-J. Stormwater Drainage Facilities.....	70
VI-K. Water Supply Systems.....	71
VI-L. Wastewater Treatment Systems.....	72
VI-M. Utilities.....	72
VI-N. Water Course and Irrigation Easements.....	73
VI-O. Disposition of Water Rights.....	74
VI-P. Park Land Dedication – Cash in Lieu – Waivers – Administration.....	75
VI-Q. Fire Protection.....	76
VI-R. Fire Protection Water Supplies.....	77
VI-S. Special Requirements for Subdivisions Proposed in Areas of High Fire Hazard.....	79
VI-T. Noxious Weeds.....	80
VI-U. Landscape Buffer.....	80
<b>VII. SUBDIVISIONS PROVIDING MULTIPLE SPACES FOR RECREATIONAL CAMPING VEHICLES OR MOBILE/MANUFACTURED HOMES.....</b>	<b>83</b>
VII-A. General.....	83
VII-A-1. Definitions.....	83
VII-A-2. Review and Approval.....	84
VII-B. Design Standards for Subdivision Providing Multiple Spaces for Rent or Lease.....	85
VII-B-1. General Design Standards for Mobile Home Parks and Recreational Vehicle Parks..	85
VII-B-2. Design Standards for Mobile/Manufactured Home Parks.....	86
VII-B-3. Design Standards for Recreational Vehicle Parks.....	87
<b>VIII. CONDOMINIUMS, TOWNHOMES OR TOWNHOUSES.....</b>	<b>88</b>

VIII-A. Exemptions.....	88
VIII-B. Procedures.....	88
VIII-C. Design Standards.....	88

**IX. DIVISIONS OF LAND EXEMPT FROM SUBDIVISION REVIEW.....90**

IX-A. Purpose.....	90
IX-B. Exemption Examination Process.....	90
IX-B-1. General Submittal and Administrative Procedures.....	90
IX-B-2. Exemption Review Criteria.....	92
IX-B-3. General Requirements for Exemptions.....	92
IX-C. Requirements for Specific Exemptions.....	93
IX-C-1. Gift or Sale to a Member of the Immediate Family.....	93
IX-C-2. Divisions of Land for Agricultural Use Only.....	95
IX-C-3. Relocation of Common Boundaries and Aggregation of Lots.....	97
IX-C-4. Exemption to Provide Security for a Construction Mortgage, Lien or Trust Indenture.....	97
IX-C-5. Division for Rights-of-Way or Utility Site.....	99
IX-C-6. Court Ordered Divisions.....	100
IX-C-7. Condominiums, Townhomes, or Townhouses.....	100
IX-C-8. Exemptions Not Requiring Action by the Planner.....	101
IX-C-9. Identification Codes.....	102

**APPENDICES**

**APPENDIX 1: UNIFORM STANDARDS FOR MONUMENTATION**

**APPENDIX 2: AGENCY CONTACTS**

**APPENDIX 3: POTENTIAL ENVIRONMENTAL PERMITS**

**APPENDIX 4: SUBDIVISION PROCESS**

**APPENDIX 5: REQUEST FOR PRE-APPLICATION MEETING**

**APPENDIX 6: MODEL NOTIFICATION LETTER**

**APPENDIX 7: PRELIMINARY PLAT APPLICATION CHECKLIST**

**APPENDIX 8: SUBDIVISION ASSESSMENT FORM**

**APPENDIX 9: VARIANCE APPLICATION**

**APPENDIX 10: RIGHT TO FARM**

**APPENDIX 11: LAND STEWARDSHIP PLAN**

**APPENDIX 12: ENVIRONMENTAL ASSESSMENT**

- APPENDIX 13: SUMMARY OF PROBABLE IMPACTS**
- APPENDIX 14: COMMUNITY IMPACT REPORT**
- APPENDIX 15: EMERGENCY SERVICES DECLARATION**
- APPENDIX 16: GROWTH POLICY COMPLIANCE CHECKLIST**
- APPENDIX 17: PRELIMINARY PLAT EXTENSION**
- APPENDIX 18: FINAL PLAT APPLICATION**
- APPENDIX 19: FINAL PLAT APPLICATION CHECKLIST**
- APPENDIX 20: MODEL SUBDIVISION IMPROVEMENTS AGREEMENT**
- APPENDIX 21: AMENDED PLAT APPLICATION**
- APPENDIX 22: SUBDIVISION EXEMPTION APPLICATION**
- APPENDIX 23: MODEL AGRICULTURAL COVENANT REMOVAL REQUEST**

**DRAFT**

## DEFINITIONS

---

Whenever the following words or phrases appear in these regulations, they shall have the meaning assigned to them by this section. When not inconsistent with the context, words used in the present tense include the future; the singular, unless otherwise specifically defined in a particular section, includes the plural, and the plural the singular; the word “shall” is always mandatory, and the word “may” indicates use of discretion in making decisions.

### 1. ACCESS (LEGAL AND PHYSICAL):

a. **Legal access** means that each lot in a subdivision either abuts a public (dedicated to the public or city, county, state, or federal) street or road, or that the subdivider has obtained adequate and appropriate easements across all necessary properties, from a public road to each lot in the subdivision, whether a road has been constructed on that property and has dedicated the easement or private road for public use or for the use of the subdivision.

b. **Physical access** means that a street or road conforming to the subdivision design standards provides vehicular access to each lot in the subdivision, either from a public street or road, from a road constructed to local road standards in the obtained easements which is dedicated to public use, or from a private road improved to local road standards which has been dedicated to public use or for the use of the subdivision. Gated communities/subdivisions are prohibited.

2. **ADJOINING LANDOWNER (ADJACENT PROPERTY OWNER):** The owner of record of a parcel of land that is contiguous, at any point, or land that is separated from the parcel by a road, watercourse, or deeded right-of-way.

3. **AGRICULTURE:** All aspects of farming, including the cultivation and tillage of the soil; dairying; and the production, cultivation, growing, and harvesting of any agricultural or horticultural commodities, including commodities defined as agricultural commodities in the federal Agricultural Marketing Act and the raising of livestock, bees, fur-bearing animals, or poultry; and any practices, including forestry or lumbering operations, performed by a farmer or on a farm as an incident to or in conjunction with farming operations, including preparation for market or delivery to storage, to market, or to carriers for transportation market, excluding any consideration of whether the proposed subdivision will result in a loss of agricultural soils.

4. **AGRICULTURAL COVENANT:** A covenant running with the land approved by the governing body which restricts the land to agricultural uses only. [Section 76-3-207(1)(c), MCA] and can only be removed pursuant to Section 76-3-211, MCA]

5. **AGRICULTURAL WATER USER FACILITIES:** Those facilities which provide water for agricultural land as defined in 15-7-202, MCA, or which provide water for the production of agricultural products as defined in 15-1-101, MCA including, but not limited to ditches, pipes, and head gates.

6. **ALIQUOT PART:** A portion of a United States government lot or section of land. For example, quarter sections are called  $\frac{1}{4}$  aliquot parts, meaning four (4) equal parts.

7. **APPLICANT:** A person, or a person’s representative or agent, who submits a subdivision application under these regulations.

8. **AQUIFER:** A layer of rock which holds water and allows water to percolate through it.
9. **ARM:** Administrative Rules of Montana.
10. **BASE FLOOD ELEVATION:** The computed elevation to which floodwater is anticipated to rise during a flood having a one percent chance of being equaled or exceeded in any given year. A base flood is the same as a flood of 100-year frequency. [36.15.101(5) ARM]
11. **BLOCK:** A group of lots, tracts, or parcels within well-defined and fixed boundaries. Such boundaries may include streets, railroads, irrigation ditches, streams, platted lands, or a combination thereof.
12. **BUILDING:** A structure having a roof supported by walls or columns, or other supports intended for the shelter or full enclosure of persons, animals, or moveable property.
13. **BUILDING ENVELOPE:** On a lot, a specified area within which any and all building construction shall occur.
14. **CASH-IN-LIEU:** A cash payment which is made by the subdivider and which equals the assessed value of the land that would otherwise have been dedicated for park purposes.
15. **CERTIFICATE OF SURVEY:** A drawing of a field survey prepared by a professional land surveyor for the purpose of disclosing facts pertaining to boundary locations. [Section 76-3-103 (1), MCA].
16. **CISTERN:** A water storage tank which is buried underground below frost level. Cistern for fire control must have proper connections.
17. **CLUSTER DEVELOPMENT:** A subdivision with lots clustered in a group of five or more lots that is designed to concentrate building sites on smaller lots while allowing other lands to remain undeveloped. [Section 76-3-103 (2), MCA]
18. **COMMERCIAL USE:** The purchase, sale, or transaction involving the disposition or storage of any article, substance, commodity, or service, maintenance or conduct of offices, professionals, or recreational or amusement enterprises conducted for profit and including renting of rooms, business offices, and sale display rooms, and premises, which includes mobile home and recreational vehicle parks.
19. **COMPREHENSIVE PLAN, MASTER PLAN, OR GROWTH POLICY:** means a comprehensive development plan, master plan, or comprehensive plan that was adopted pursuant to Title 76, Chapter 1, MCA, before October 1, 1999, or a policy that was adopted pursuant to Title 76, Chapter 1, MCA, on or after October 1, 1999. When a growth policy has been approved, subdivision regulations must be made in accordance with the growth policy. [Section 76-1-606, MCA]
20. **CONDOMINIUM:** A form of individual ownership with unrestricted right of disposal of one or more units in a multiple unit project, with the land and other parts of the project held in common ownership or use with owners of the other units, pursuant to Title 70, Chapter 23, MCA.

- 21. CONSERVATION EASEMENT:** A voluntary legal agreement between a landowner and a land trust or government agency that permanently restricts certain land uses and activities in order to protect the conservation values associated with the property's natural resources, natural topography, or wildlife habitat.
- 22. COVENANT (RESTRICTIVE COVENANT):** A limitation contained in a deed or other document that restricts or regulates the use of the real property.
- 23. COUNTY ROAD IN SUBDIVISION:** A road on a final subdivision plat that is dedicated to public use is not considered a county road until the Board of County Commissioners approves by resolution the adoption of the road as a county road. [Section 7-14-2101(2)(d), MCA]
- 24. DEDICATION:** The deliberate appropriation of land by an owner for any general and public use, reserving to the landowner no rights that are incompatible with the full exercise and enjoyment of the public use to which the property has been devoted. [Section 76-3-103 (3), MCA]
- 25. DEFENSIBLE SPACE:** The buffer zone between a structure and the surrounding area to slow or halt the progress of fire.
- 26. DEQ:** The Montana Department of Environmental Quality.
- 27. DIVISION OF LAND:** The segregation of one or more parcels of land from a larger tract held in single or undivided ownership by transferring or contracting to transfer title to or possession of a portion of the tract or properly filing a certificate of survey or subdivision plat establishing the identity of the segregated parcels pursuant to the MSPA. The conveyance of a tract of record or an entire parcel of land that was created by a previous division of land is not a division of land. [Section 76-3-103 (4), MCA]
- 28. DRIVEWAY:** A vehicular access way that typically serves up to two residences.
- 29. DRY HYDRANT:** A pipe that leads to a water source but has no pressure of its own. Firefighters attach a pump to dry hydrants and draft water from the water source to supply water to apparatus. The portion of the piping containing water must be below frost level.
- 30. DWELLING UNIT:** Any structure or portion thereof providing complete, independent, and permanent living facilities for one household. Also defined as a residential structure in which a person or persons reside. [Section 76-3-621(10)(b), MCA]
- 31. EASEMENT:** A nonpossessory interest in land that gives a person or entity the right to use the land of another for a specific purpose or purposes including but not limited to irrigation, roadway ingress/egress, recreation, utilities, or emergency vehicle access.
- 32. EMERGENCY SERVICES:** Community services such as fire protection, law enforcement, ambulance service, quick response, search and rescue, flood and disaster relief.
- 33. EMPLOYEE HOUSING:** Housing in a development occupied by those individual(s) (often including their families) who are employed by a business providing direct services to that development.

- 34. ENGINEER (PROFESSIONAL ENGINEER):** A person licensed and registered in conformance with the Montana Engineers' and Land Surveyors' Act [Title 37, Chapter 67, MCA] to practice engineering in the State of Montana.
- 35. ENVIRONMENTAL ASSESSMENT:** A component of a subdivision application for major subdivisions that provides information needed for the assessment of impacts from subdivision on agriculture, agricultural water users' facilities, local services, national environment, wildlife, wildlife habitat, and public health and safety. The contents of an Environmental Assessment shall be pursuant to Section 76-3-603, MCA.
- 36. EROSION:** The process by which the soil and rock components of the earth's crust are worn away and removed from one place to another by natural forces such as water, wind, ice, and gravity.
- 37. EXAMINING LAND SURVEYOR:** A registered land surveyor appointed by the governing body to review surveys and plats submitted for filing. [Section 76-3-103(5), MCA]
- 38. EXEMPTION REVIEW BOARD:** A board which acts under the Montana Subdivision and Platting Act to review, approve, conditionally approve, or deny subdivision exemption requests. In Madison County, the Exemption Review Board is composed of the Clerk and Recorder, Sanitarian, and Planner, or their designated alternates.
- 39. EXPEDITED SUBDIVISION REVIEW:** An expedited review process for subdivisions that meet the requirements for the review process. A county must opt into this statutory review process by resolution. [Section 76-3-623, MCA]
- 40. FINAL PLAT:** The final drawing of the subdivision and dedicate required by the MSPA to be prepared for filing for record with the County Clerk and Recorder and containing all elements and requirements set forth in the MSPA and these subdivision regulations. [Section 76-3-103(6), MCA]
- 41. FINDING OF FACT:** A written conclusion or determination based on evidence made in support of a decision.
- 42. FISH HABITAT (ESSENTIAL FISH HABITAT):** Those waters and substrate necessary for spawning, breeding, feeding, or growth to maturity.
- 43. FLOOD:** The water of any watercourse or drain way that is above the bank or outside the channel and banks of such watercourse or drainway. [Section 76-5-103 (8), MCA]
- 44. FLOOD HAZARD AREA:** The area at and below the base flood elevation.
- 45. FLOOD OF 100 YEAR FREQUENCY:** A flood magnitude expected to recur on the average of once every 100 years or a flood magnitude that has a 1% chance of occurring in any given year. [Section 76-5-103 (9), MCA]
- 46. FLOODPLAIN:** The area adjoining the watercourse or drainway that would be covered by the floodwater of a flood of 100-year frequency. [Section 76-5-103 (10), MCA].

- 47. FLOODWAY:** The channel of a watercourse or drainway and those portions of the floodplain adjoining the channels that are reasonably required to carry and discharge the floodwater of any watercourse or drain way. [Section 76-5-103 (11), MCA]
- 48. GEOGRAPHIC INFORMATION SYSTEM:** A computer system for capturing, sorting, checking, and displaying data related to positions on Earth's surface, used to better understand spatial patterns and relationships.
- 49. GOVERNING BODY:** The governing authority of Madison County organized pursuant to law. [Section 76-3-103 (7), MCA]
- 50. GUARANTY:** Refers to an undertaking to answer for the payment of a debt or the performance of a duty of another in case of the other's financial default.
- 51. HAZARD:** Any condition, either natural or man-made, which presents danger to the public health, safety, and welfare.
- 52. HIGH FIRE HAZARD AREAS:** Heads of draws, steep slopes, dense forest growth, or other hazardous wildfire components. Areas that may require additional fire protection measures such as two ingress-egress routes, sprinkler systems, defensible space, specific building materials, and other mitigation measures.
- 53. HISTORIC RESOURCE:** Any prehistoric or historic district, site, building, structure, or object included in, or eligible for inclusion on, the National Register of Historic Places, including artifacts, records, and material remains related to such a property or resource.
- 54. HOMEOWNERS ASSOCIATION:** A corporation organized under the provision of Title 35, Chapter 2 (MCA) that is responsible for the operation of a community or a mobile home subdivision. [Section 35-2-525, MCA]
- 55. HOUSING DEDICATION:** A dedication of real property is prohibited, which includes a payment or other contribution to a local housing authority or the reservation of real property for future development of housing for specified income levels or specified sale prices. [Section 76-3-514, MCA]
- 56. HYDROLOGY:** The properties of water, including circulation and distribution, on and below the ground.
- 57. IMMEDIATE FAMILY:** A spouse, children by blood or adoption, and parents.
- 58. IMPROVEMENT AGREEMENT:** A contractual agreement that may be required by the governing body to ensure the construction of such improvements as required by local subdivision regulations. The improvement agreement may require collateral to secure the construction of such improvements, such as the deposit of certified funds, irrevocable letters of credit, performance, or property bonds, private or public escrow agreements, or similar financial guarantees. [Section 76-3-507, MCA]

**59. INDUSTRIAL USE:** The manufacture, fabrication, processing or reduction of any article, substance, or commodity or any other treatment thereof in such a manner to change the form character or appearance thereof. It shall include trucking facilities, rail facilities, mining, warehousing, and product, materials or equipment storage, and businesses serving primarily industry and similar enterprises.

**60. INFRASTRUCTURE:** The set of interconnected structural elements that provide a framework supporting an entire structure of development.

**61. LANDOWNER:** All individuals, groups, or parties with a title interest in the property. For purposes of Section 76-3-207, MCA, when a parcel of land for which an exemption from subdivision review is claimed is being conveyed under a contract-for-deed, the terms “property owner,” “landowner,” and “owner” mean the seller of the parcel under the contract-for-deed (24.183.1104 ARM). For all other purposes of these regulations, the terms “property owner,” “landowner,” and “owner” mean both the seller and the purchaser under a contract for deed.

**62. LAND STEWARDSHIP PLAN:** A long-term management plan that outlines how such things as vegetative health, public access, wildlife, livestock grazing, other agricultural uses, waste management, and protection of natural resources will be addressed.

**63. LOCAL FIRE AUTHORITY:** A local fire district, fire service area, or the county fire marshal. [Title 7, Chapter 33, MCA]

**64. LOCAL SERVICES:** Any and all services or facilities that local government entities are authorized to provide.

**65. LOT:** A parcel, plot, or other land area created by subdivision.

**66. LOT MEASUREMENT:**

- a. **Lot Depth:** The length of a line drawn perpendicularly to the front lot line and extending to the rear lot line.
- b. **Lot Width:** The average width of the lot.
- c. **Lot Frontage:** The width of the front lot line.
- d. **Net Lot Area:** The gross lot area less the area within any existing or proposed public or private street, road or easement for ingress and egress, and less the area within any existing or proposed easement wherein the owner of the lot is prohibited from using the surface of the land. Included in the net area is the area lying within public utility easements, sanitary sewer easements, landscaping easements, and other such easements wherein the owner of the lot is not prohibited from using the surface of the land.
- e. **Gross Lot Area:** The total area, measured in a horizontal plane, within the boundary lines of a lot.

**67. LOT TYPES:**

- a. **Corner Lot:** A lot located at the intersection of two streets.
- b. **Interior Lot:** A lot with frontage on only one street.

- c. **Through or Double-Frontage Lot:** A lot whose front and rear lines both abut on streets.
- d. **Flag Lot:** A lot of irregular shape, the bulk of which is normally situated to the rear of other lots, having as its frontage and access a drive connecting it to a street.

**68. MAJOR SUBDIVISION:** A subdivision that creates six or more lots.

**69. MCA:** Montana Code Annotated.

**70. MINOR SUBDIVISION:** A subdivision that creates five or fewer lots from a tract of record. [Section 76-3-103(9), MCA].

- a. **ADMINISTRATIVE MINOR SUBDIVISION:** A subdivision meeting the requirements of subsection 76-3-609(6), MCA.
- b. **FIRST MINOR SUBDIVISION:** A proposed subdivision of a tract of record that:
  - i. has not been subdivided or created by a subdivision; or
  - ii. has not resulted from a tract of record that has had more than five parcels created from that tract of record under Section 76-3-201 or 76-3-207, MCA since October 1, 2003. [Section 76-3-609(2), MCA]
- c. **SUBSEQUENT MINOR SUBDIVISION:** A proposed subdivision which is the second or subsequent minor subdivision that does not result in a total of more than five parcels created by subdivision or has not resulted from a tract of record that has had more than five parcels created from that tract of record under 76-3-201 or 76-3-207 since October 1, 2003. [Section 76-3-609(2), MCA].

**71. MOBILE (MANUFACTURED) HOME:** A detached residential dwelling unit, which may consist of two or more sections, designed to be towed on its own chassis to a building site for occupation as a dwelling with or without a permanent foundation, which in the traveling mode is eight body feet or more in width or forty body feet or more in length, or, when erected on-site is 320 or more square feet in size. Mobile homes are designed to be used as a dwelling for human occupancy upon connection to required utilities, including plumbing, heating, and electrical systems. The term includes, but is not limited to, "trailer homes," "house trailers," and "manufactured homes" whether the unit has been constructed after July 1, 1976, in conformance with Federal Manufactured Home Construction and Safety Standards. The term does not include "modular" or "factory-built buildings" that are fabricated at a factory in accordance with the Uniform Building Code Standards applicable to site-built homes and are transported to the site for final assembly on a permanent foundation. [42 U.S.C. 3535(d), 5403, 5404, and 5424].

**72. MOBILE (MANUFACTURED) HOME SPACE:** A designated portion of a parcel of land designed for the accommodation of one mobile home and its accessory buildings or structures for the exclusive use of the occupants.

**73. MOBILE (MANUFACTURED) HOME PARK:** A tract of land that provides or will provide two or more spaces for rent or lease in which a mobile home will be placed. [Section 70-33-103(11), MCA]

- 74. MOBILE (MANUFACTURED) HOME PAD:** That area of a mobile home space which has been prepared for the placement of a mobile home.
- 75. MONTANA DEPARTMENT OF ENVIRONMENTAL QUALITY MINIMUM STANDARDS:**  
Minimum standards promulgated by the Montana Department of Environmental Quality, pursuant to Title 76, Chapter 4, Part 1, MCA.
- 76. MONUMENT (PERMANENT MONUMENT):** Any structure of masonry, metal, or other permanent, durable material placed in the ground, which is exclusively identifiable as a monument to a survey point, expressly placed for surveying reference. [24.183.1101(1)(a) ARM]
- 77. MSPA:** Montana Subdivision and Platting Act, Title 76, Chapter 3, MCA.
- 78. MUNICIPALITY:** An incorporated city or town.
- 79. NATURAL ENVIRONMENT:** The physical conditions which exist within a given area, including land, air, water, minerals, flora, fauna, sound, light, and objects of historic and aesthetic significance.
- 80. NATURAL RESOURCES:** The natural resources of the state and county including land, soils, natural wild and scenic areas, timber and forests, minerals, farm and grazing lands, groundwater and surface water, fish and wildlife, and biotic communities.
- 81. NO BUILD ZONE:** An area in which no structure may be constructed or otherwise placed, including buildings, culverts, irrigation facilities, earthen dams or berms, storage facilities, or any structures that may impede stormwater drainage areas, etc. A No Build Zone is generally intended to mitigate potentially adverse impacts.
- 82. NOXIOUS WEED:** Any exotic plant species established or that may be introduced in the state that may render land unfit for agriculture, forestry, livestock, wildlife, or other beneficial uses or that may harm native plant communities and that is designated as a statewide noxious weed by rule of the department or as a district noxious weed by a board, following public notice of intent and a public hearing. [Section 7-22-2101(9)(a), MCA]
- 83. OPEN SPACE:** Land or water areas retained for perpetual use as active or passive recreation areas or for resource protection in an essentially undeveloped state. Open space land is preserved for park or recreational purposes, conservation of land or other natural resources, historic or scenic purposes, or assisting in the shaping of the character, direction, and timing of community development.
- 84. ORDINARY/MEAN HIGH-WATER MARK:** The line that water impresses on land by covering it for sufficient periods to cause physical characteristics that distinguish the area below the line from the area above it. Characteristics of the area below the line include, when appropriate, but are not limited to deprivation of the soil of substantially all terrestrial vegetation and destruction of its agricultural vegetative value. [36.2.402(6) A.R.M.]
- 85. PHASED DEVELOPMENT:** A subdivision application and preliminary plat that at the time of submission consists of independently platted development phases that are scheduled for review on a schedule proposed by the subdivider. [Section 76-3-103(10), MCA]

- 86. PLANNER:** The planning staff for Madison County; also the Subdivision Administrator.
- 87. PLANNING BOARD:** A planning board formed pursuant to Title 76, Chapter 1, MCA.
- 88. PLAT:** A graphical representation of a subdivision showing the division of land into lots, parcels, blocks, streets, alleys, and other divisions and dedications. [Section 76-3-103 (12), MCA].
- a. **Preliminary Plat:** A neat and scaled drawing of a proposed subdivision showing the layout of streets, alleys, lots, blocks, and other elements of a subdivision that furnish a basis for review by a governing body as more specifically set forth in these regulations and the MSPA. [Section 76-3-103(13)].
  - b. **Final Plat:** The final drawing of the subdivision and dedication required to be prepared for filing for record with the county clerk and recorder containing all elements and requirements set forth in these regulations and the MSPA. [Section 76-3-103(6), MCA].
  - c. **Amended Plat:** The final drawing of any change to a filed platted subdivision, or any lots within a filed platted subdivision.
  - d. **Vacated Plat:** A plat which has been voided under the provisions of Sections 76-3-305, 7-5-2501, 7-5-2502, 7-14-2616 (1) and/or (2), 7-14-2617, 7-14-4114 (1) and/or (2), and 7-14-3115, MCA.
- 89. PLATTED COVENANT:** A limitation contained on the face of the plat that restricts or regulates the use of the real property.
- 90. PRE-APPLICATION SKETCH (OR DRAWING):** A legible drawing showing approximate boundaries, dimensions, areas, distances, and other pertinent information of a proposed subdivision. [Section 76-3-504(q), MCA]
- 91. PRIVATE IMPROVEMENT:** Private improvements are the same types of improvements as defined under PUBLIC IMPROVEMENTS, except the structure or facility has not been dedicated to the public or otherwise acquired by a government entity for public use.
- 92. PRIVATE ROAD:** A road is private if its right-of-way has neither been dedicated to nor acquired for public use. A private road may be open to use by the public or public access may be restricted.
- 93. PUBLIC HEALTH AND SAFETY:** Condition of optimal well-being, free from danger, risk, or injury for a community at large, or for all people, not merely for the welfare of a specific individual or a small class of persons.
- 94. PUBLIC IMPROVEMENT:** Any structure or facility constructed to serve more than one lot in a subdivision which is dedicated to the public, for the use of the subdivision, or otherwise acquired by a government entity for public use. Examples of typical public improvements include parks, streets or roads, sidewalks, curbs, gutters, and street lighting, utilities, and systems for water supply, sewage disposal, drainage, or fire protection.
- 95. PUBLIC ROAD OR STREET:** A road or street is public if its right-of-way has been dedicated to or acquired for public use.

- 96. PUBLIC SERVICES:** Services and facilities provided to the general community by government or quasi-public entities.
- 97. PUBLIC USE:** Easements or rights-of-way providing vehicular or pedestrian access to and within a subdivision which are dedicated for full public use and access, excluding overnight camping and occupancy. Public use rights-of-way may be utilized by adjacent landowners or subdivision, given that proper written permission has been granted; public rights-of-way owners may require monetary agreements for use agreements extending beyond properties immediately adjacent to or originally served by the easements or rights-of-way.
- 98. RECREATIONAL CAMPING VEHICLE:** A vehicular type unit primarily designed as temporary living quarters for recreational, camping, or travel use that either has its own motor power or is mounted on or drawn by another vehicle. The basic types of RVs are camping trailers, fifth wheel trailer, motor home, park trailer, travel trailer, and truck camper. Recreational Camping Vehicles are designed to be used as a temporary living quarter for human occupancy without connection to required utilities, including plumbing, heating, and electrical systems. [Section 50-60-101(16), MCA]
- 99. RECREATIONAL VEHICLE PAD:** A designated location in a Recreational Vehicle Space that identifies where recreational vehicles must park during occupation, and where all other uses unless specifically authorized are prohibited.
- 100. RECREATIONAL VEHICLE PARK:** A tract of land where two or more spaces for rent or lease in which a recreational vehicle will be placed, that is available to and principally used by the public for camping. [Section 76-3-103(16), MCA]
- 101. RECREATIONAL VEHICLE SPACE:** A designated portion of a recreational vehicle park designed for the placement of a single recreational vehicle, the exclusive use of its occupants and their personal belongings including automobiles, outdoor storage etc.
- 102. RESIDENTIAL USE:** A structure or dwelling unit designed for permanent occupancy by a single-family or multi-family that contains facilities for cooking, living, and sleeping. These units include boarding or rooming houses. Residential use does not include transient accommodations, such as: hotels, motels, dormitories, or fraternity or sorority houses.
- 103. REVIEWING AUTHORITY:** The DEQ or local Board of Health or Sanitarian as authorized under Title 76, Chapter 4, MCA.
- 104. RIGHTS-OF-WAY:** A linear public way established or dedicated for public purposes by a duly recorded plat, deed, easement, grant, prescription, condemnation, governmental authority or by operation of law, intended to be occupied by a street, non-motorized vehicle path, railroad, electric transmission lines, water line, sanitary sewer line, storm sewer line, or other similar uses.
- 105. RIGHT TO FARM:** A Montana state law which excludes standard agricultural practices from being considered “nuisances”. [27-30-101, MCA]
- 106. RIPARIAN AREAS:** Plant communities contiguous to and affected by surface and subsurface hydrologic features of perennial or intermittent lotic and lentic water bodies (rivers, streams, lakes, or drainage ways). Riparian areas are usually transitional between wetland and upland.

- 107. RUNOFF:** Precipitation that flows off the land without filtering into the soil or being absorbed by plant material.
- 108. SETBACK:** The minimum distance structures may be located from lot lines, rights-of-ways, water courses, waterbodies, riparian areas, or other sensitive features.
- 109. SITE PLAN:** A scaled drawing that shows the existing and proposed conditions of a site or area of land proposed for development.
- 110. SLOPE:** The inclination of the surface of the land from the horizontal, prior to development.
- 111. STATE:** The State of Montana.
- 112. STREAM:** A body of running water, such as a river or creek, flowing on the earth.
- Ephemeral Stream:** A stream that flows infrequently, usually only following precipitation events or snowmelt. This could include many gullies, coulees, and draws.
  - Intermittent Stream:** A stream that flows more often than not but may not flow a good portion of the time in all reaches. For example, during late summer there may be flow in some sections of an intermittent stream and no flow in other reaches where water seeps into the stream bottom at a higher rate.
  - Perennial Stream:** A stream that typically flows all year for its entire length during non-drought years.
- 113. STRUCTURE:** A structure is defined as any artificial obstruction. This includes, but is not limited to, buildings, culverts, irrigation facilities, earthen berms or dams, or fences.
- 114. SUBDIVIDER:** Any person, firm or corporation, or other entity which causes land to be subdivided or which proposes a subdivision of land [Section 76-3-103 (15), MCA]. When used in these regulations, the term "subdivider" may also include the property purchaser on a contract for deed or its agent, or the landowner's agent, if the landowner has provided the planner written notification that the landowner's agent is authorized to act on the landowner's behalf and to receive notices regarding local government decisions concerning the subdivision.
- 115. SUBDIVISION:** A division of land or land so divided which creates one or more parcels containing less than 160 acres that cannot be described as a one-quarter aliquot part of a United States government section, exclusive of public roadways, in order that the title to the parcels may be sold or otherwise transferred and includes any re-subdivision and a condominium. The term also means an area, regardless of its size, that provides or will provide multiple spaces for rent or lease on which recreational camping vehicles or mobile homes. [Section 76-3-103 (16), MCA]
- 116. SUBDIVISION ADMINISTRATOR:** The "planner"; the person or persons authorized by the governing body to perform the duties of review and administration set forth in these regulations.
- 117. SUBDIVISION EXEMPTION:** A division of land which, in accordance with the Montana Subdivision and Platting Act, is not subject to review as a subdivision.

- 118. SURVEYOR (PROFESSIONAL LAND SURVEYOR):** A person licensed in conformance with the Montana Engineers' and Land Surveyors' Act (Title 37, Chapter 67, MCA) to practice surveying in the State of Montana.
- 119. SURVEYOR (EXAMINING LAND SURVEYOR):** A professional land surveyor duly appointed by the governing body to review surveys and plats submitted for filing. [Section 76-3-103(5), MCA].
- 120. SWALE:** A drainage channel or depression designed to direct surface water flow.
- 121. SUBDIVISION GUARANTY:** A report from an authorized title insurer or title insurance producer on the condition of title to the property proposed for subdivision, which identifies the owners of record of the property, lien holders, encumbrances, easements and restrictions of record, and all other conditions of title of public record, and accompanied by a guarantee of the accuracy of the report from the title insurance agent or its underwriter. [Section 76-3-612, MCA]
- 122. TOPOGRAPHY:** General term to include characteristics of the ground surface such as plains, hills, mountains, slopes, and other physiographic features.
- 123. TOWNHOME or TOWNHOUSE:** Property that is owned subject to an arrangement under which persons own their own units and hold separate title to the land beneath their units, but under which they may jointly own the common areas and facilities. [Section 70-23-102(18), MCA]
- 124. TRACT OF RECORD:** An individual parcel of land, irrespective of ownership, that can be identified by legal description, independent of any other parcel of land, using documents on file in the records of the county clerk and recorder's office. [Section 76-3-103 (17)(a), MCA]
- 125. U.S.C:** United States Code.
- 126. VARIANCE:** A device which grants a property owner relief from a regulation standard, where strict enforcement of the standard would create a hardship upon the owner.
- 127. VICINITY SKETCH:** A map at a scale suitable to locate a proposed subdivision, showing the boundary lines of all adjacent properties and streets and other information necessary to determine the general location of the proposed subdivision all as more particularly set forth in Subsection II-A-1 of these regulations.
- 128. VIEWSHED:** The natural environment that is visible from one or more viewing points.
- 129. WATER AND SANITATION INFORMATION:** The information required under 76-3-622, MCA, and to be submitted with the subdivision application. [Section 76-3-601(1), MCA]
- 130. WATER BODY:** Includes rivers, streams, creeks, lakes, and ponds, both natural and man-made, both intermittent and year-round. The term does not include any facility created exclusively for the conveyance of irrigation water.
- 131. WATERCOURSE:** Any depression two feet or more below the surrounding land serving to give direction to a current of water at least nine months of the year and having a bed and well-defined banks. [Section 76-5-103(16), MCA]

- 132. WATER RIGHT:** The right to appropriate water pursuant to an existing right, a permit, a certificate of water right, a state water reservation, or a compact. [Section 85-2-102, MCA]
- 133. WETLAND:** As defined by the US Army Corps of Engineers, (jurisdictional) wetlands are those areas that are inundated or saturated by surface or ground water at a frequency and duration sufficient to support, and that under normal circumstances do support, a prevalence of vegetation typically adapted for life in saturated soil conditions.
- 134. WILDLIFE:** Living things which are neither human nor domesticated.
- 135. WILDLIFE HABITAT:** Place or type of site where wildlife naturally lives and grows.
- 136. WILDLAND URBAN INTERFACE (WUI):** The zone of transition between unoccupied land and human development. Or, according the US Forest Service, the place where humans and their development meet or intermix with wildland fuels.

DRAFT

# I. GENERAL PROVISIONS

---

## I-A. Title

These regulations will be known and may be cited as “The Madison County Subdivision Regulations”; hereinafter referred to as “these regulations.”

## I-B. Authority

Authorization for these regulations is contained in the Montana Subdivision and Platting Act (“MSPA”) [Title 76, Chapter 3, MCA].

## I-C. Purpose

The purposes of these regulations are to promote the public health, safety, and general welfare by regulating the subdivision of land; to prevent the overcrowding of land; to lessen congestion in the streets and highways; to provide for adequate light, air, water supply, sewage disposal, parks and recreation areas, ingress and egress, and other public requirements; to require development in harmony with the natural environment; to promote preservation of open space; to promote cluster development approaches that minimize costs to local citizens and that promote effective and efficient provision of public services; to protect the rights of property owners; and to require uniform monumentation of land subdivisions and transferring interests in real property by reference to a plat or certificate of survey, and provide for phased development. [Section 76-3-102, MCA].

These regulations are intended to comply with MCA, Title 76, Part 5 of the MSPA, and are intended to promote:

1. The orderly development of the jurisdictional area.
2. The coordination of roads within subdivided land with other roads, both existing and planned.
3. The dedication of land for roadways and for public utility easements.
4. The improvement of roads.
5. The provision of proper physical and legal access, including obtaining necessary easements.
6. The provision of adequate open spaces for travel, light, air, and recreation.
7. The provision of adequate transportation, water, drainage, and sanitary facilities.
8. The avoidance or minimizing of congestion.
9. The avoidance of subdivisions which would involve unnecessary environmental degradation.
10. The avoidance of danger or injury by reason of natural hazard or the lack of water, drainage, access, transportation, or other public improvements.
11. The avoidance of excessive expenditure of public funds for the supply of public improvements and services.
12. The manner and form of making and filing of any plat for subdivided lands.
13. The administration of these regulations by defining the powers and duties of approving authorities, including procedures for the review and approval of all plats of subdivisions covered by these provisions.

## I-D. Jurisdiction

These regulations govern the subdivision of land within the jurisdictional area of the governing body of Madison County.

If a proposed subdivision lies within one mile of a third-class city or town or within two miles of a second-class city or within three miles of a first-class city, the County governing body must submit the preliminary plat to the city or town governing body or its designated agent for review and comment. If a proposed subdivision lies partly within an incorporated city or town, the preliminary plat must be submitted to, and approved by, both the city or town and the County governing body.

If a proposed subdivision is in a rural school district, the governing body shall provide a summary of the information contained in the subdivision application and preliminary plat to school district trustees.

When a proposed subdivision is also proposed to be annexed to a municipality, the governing body of the municipality will combine public hearings and otherwise coordinate the subdivision review process and annexation procedures whenever possible. [Section 76-3-601(2), MCA].

These regulations supplement all other regulations, and where they are at variance with other laws, regulations, ordinances, or resolutions, the more restrictive requirements apply. Other regulations include, but are not limited to, zoning regulations, Floodplain Development regulations, development codes, Buildings for Lease or Rent regulations, Airport Affected Area regulations, and fire codes.

#### **I-E. Severability**

If a court of competent jurisdiction holds any word, phrase, clause, sentence, paragraph, section, or other part of these regulations invalid, that judgment will affect only the part held invalid.

#### **I-F. Public Hearing and Notice**

##### **a. Hearing**

- i. Public hearings for major subdivisions shall be held by the Planning Board. When applicable, a subsequent public hearing(s) shall be held by the governing body.
- ii. When a hearing is required by these regulations, notice shall be posted according to the requirements in Subsection I-F (b) below.

##### **b. Notice**

- i. The Planning Board shall give notice of the time, dates, and location of the hearing by publication in a newspaper of general circulation in the County not less than 15 days prior to the date of the hearing.
- ii. At least 15 days prior to the date of the hearing, the Planning Board shall give notice of the hearing by certified mail to the subdivider, each adjoining landowner to the land included in the preliminary plat, and each purchaser under contract for deed of property immediately adjoining the land included in the preliminary plat.

### **I-G. Construction Timing**

A person may not erect any facility for supply of water, disposal of sewage or solid waste, erect any building or shelter that requires facilities for the supply of water, disposal of sewage, or solid waste until the governing body has given conditional approval of the preliminary plat. In addition, a person shall not begin construction on facilities to be used by the public such as roads, parks or utilities until the governing body has given conditional approval of the preliminary plat. Construction work undertaken prior to the preliminary plat approval subjects the subdivider to the possibility the work will have to be redone or removed.

### **I-H. Transfer of Title**

Except as noted below, a final subdivision plat must be filed for record with the County Clerk and Recorder before title to the subdivided land can be sold or transferred in any manner. After the preliminary plat of a subdivision has been approved or conditionally approved, the subdivider may enter into contracts to sell lots in the proposed subdivision if all the following conditions are met [Section 76-3-303, MCA]:

- a. That under the terms of the contracts the purchasers of lots in the proposed subdivision make any payments to an escrow agent, which must be a bank or savings and loan association chartered to do business in the State of Montana;
- b. That under the terms of the contracts and the escrow agreement the payments made by purchasers of lots in the proposed subdivision may not be distributed by the escrow agent to the subdivider until the final plat of the subdivision is filed with the County Clerk and Recorder;
- c. That the contracts and the escrow agreement provide that if the final plat of the proposed subdivision is not filed with the County Clerk and Recorder within two years of the preliminary plat approval, the escrow agent shall immediately refund to each purchaser any payments made under the contract;
- d. That the contracts contain the following language conspicuously set out therein: "The real property which is the subject hereof has not been finally platted, and until a final plat identifying the property has been filed with the County Clerk and Recorder, title to the property cannot be transferred in any manner;" and
- e. That the County Treasurer has certified that no real property taxes assessed and levied on the land to be divided are delinquent.

### **I-I. Permission to Enter**

The governing body or its designated agent(s) or affected agencies identified during the pre-application meeting may investigate, examine, and evaluate the site of the proposed subdivision to verify information provided by the subdivider and to subsequently monitor compliance with any conditions if the preliminary plat is approved conditionally. The submission of a subdivision application constitutes a grant of permission by the subdivider for the governing body, its agents, and affected agencies to enter the subject property. This consent applies to members of the public attending a noticed public meeting being held by the Planning Board or governing body for a site visit. Site visits by the Planning Board or governing body are for the sole purpose of viewing site-specific features of the property or

subdivision proposal and shall include proper public meeting notification requirements, be open to the public, include comment/discussion on the site-specific features of the property which shall be captured in the form of minutes, and a report provided at the next meeting of the Planning Board or governing body.

## **I-J. Variances**

### **I-J-1. Variances Authorized**

The governing body may grant variances from Section VI, Design and Improvement Standards, of these regulations when, due to the characteristics of land proposed for subdivision, strict compliance with these standards would result in undue hardship and would not be essential to public welfare. A variance will not be granted if it would have the effect of nullifying the intent and purpose of these regulations.

a. A public hearing is required to be held for variance requests for all major subdivisions. The public hearing shall be held by the Planning Board pursuant to Subsection I-F (a). Notice of the hearing on the variance request must be posted according to Subsection I-F (b). Public hearings are not required for variance requests for first minor subdivisions.

### **I-J-2. Variances from Floodway Provisions Not Authorized**

The governing body will not, by variance, permit subdivision for building purposes in areas located within the floodway of a flood of 100-year frequency as defined by Title 76, Chapter 5, MCA.

### **I-J-3. Variance Criteria**

The governing body will not approve a variance unless it finds that:

- a. The granting of the variance will not be detrimental to the public health, safety, or general welfare or injurious to other adjoining properties;
- b. Due to the physical surroundings, shape, or topographical conditions of the property involved, strict compliance with the regulations will impose an undue hardship on the owner. Undue hardship does not include personal or financial hardship, or any hardship that is self-imposed;
- c. The variance will not cause a substantial increase in public costs; and
- d. The variance will not place the subdivision in nonconformance with any adopted zoning regulations.

[See Section 76-3-506, MCA].

### **I-J-4. Procedure**

The subdivider shall include with the submission of the preliminary plat a written statement describing and justifying the requested variance. If during the review period a need for a variance is identified, and the variance has not been specifically requested, the application can be deemed

insufficient, and the review period can be suspended until the issue is determined to be sufficiently addressed. For applications being considered by the Planning Board, the Planning Board will consider the requested variance and recommend its approval or denial to the governing body. Variances will be considered before the analysis of the impacts of the subdivision on the primary review criteria.

#### **I-J-5. Conditions**

In granting variances, the governing body may impose reasonable conditions to secure the objectives of these regulations.

#### **I-J-6. Statement of Facts**

When a variance is granted, the motion to approve the proposed subdivision must contain a statement describing the variance and the facts and conditions upon which the issuance of the variance is based.

#### **I-K. Amendment of Regulations**

Before the governing body amends these regulations, both the Planning Board and the governing body will hold public hearings on the proposed amendment. Notice of the time and place of the public hearing must be published in a newspaper of general circulation in the County not less than 15 days or more than 30 days before the date of the hearing.

#### **I-L. Administration**

##### **I-L-1. Enforcement**

Except as provided in Section 76-3-303, MCA, and Section I-H of these regulations, every final subdivision plat must be filed for record with the County Clerk and Recorder before title to the subdivided land can be sold or transferred in any manner. If unlawful transfers or uses are made, the County Attorney shall commence action to enjoin further sales or transfers and compel compliance with all provisions of the MSPA and these regulations. The cost of this action shall be imposed against the party not prevailing. [See Section 76-3-301, MCA]

##### **I-L-2. Violation and Penalties**

Any person, firm, corporation, or other entity who violates any of the provisions of the MSPA or these regulations is guilty of a misdemeanor punishable by a fine of not less than \$100 nor more than \$500 or by imprisonment in jail for not more than three months or by both fine and imprisonment. Each sale, lease, or transfer, or offer of sale, lease, or transfer of each separate parcel of land in violation of any provision of the MSPA or these regulations shall be deemed a separate and distinct offense. [See Section 76-3-105, MCA]

##### **I-L-3. Schedule of Fees**

The required fee shall accompany the preliminary plat and final plat application. [Section 76-3-604(1), MCA]. The review fee shall be paid to the Planning Department for each application

reviewed according to the fee schedule as approved and established by the governing body under a separate document. No action shall be taken on applications or appeals until all application fees have been paid in full. The governing body may require the subdivider to pay for third party review fees, such as: Examining Land Surveying, Engineering, Montana Department of Environmental Quality, and other planning consulting review fees and outside legal review if necessary. The current review fees are available from the Planning Department or the Clerk and Recorder.

#### **I-L-4. Appeals**

- a. A person who has filed with the governing body an application for a subdivision under the MSPA and these regulations may bring an action in district court to sue the governing body to recover actual damages caused by a final action, decision, or order of the governing body or a regulation adopted pursuant to the MSPA that is arbitrary, capricious or unlawful within 180 days of the final action, decision, order or adoption of a regulation.
- b. A party identified in Subsection (d) below who is aggrieved by a decision of the governing body to approve, conditionally approve, or deny an application and preliminary plat for a proposed subdivision or a final subdivision plat may, within 30 days after the written decision, appeal to the district court in the county in which the property involved is located. The petition must specify the grounds upon which the appeal is made. The governing body's decision, based on the record as a whole, must be sustained unless the decision being challenged is arbitrary, capricious, or unlawful.
- c. For the purposes of this section, "aggrieved" means a person who can demonstrate a specific personal and legal interest, as distinguished from a general interest, who has been or is likely to be specially and injuriously affected by the decision.
- d. The following parties may appeal under the provisions of these regulations above in Subsection (b):
  - i. the subdivider;
  - ii. a landowner with a property boundary contiguous to the proposed subdivision or a private landowner with property within the county or municipality where the subdivision is proposed if that landowner can show a likelihood of material injury to the landowner's property or its value;
  - iii. the county commissioners of the county where the subdivision is proposed; and
  - iv. one of the following municipalities:
    - a first-class municipality as described in Section 7-1-4111, MCA, if a subdivision is proposed within 3 miles of its limits;
    - a second-class municipality, as described in Section 7-1-4111, MCA, if a subdivision is proposed within 2 miles of its limits;
    - a third-class municipality, as described in Section 7-1-4111, MCA, if a subdivision is proposed within 1 mile of its limits.

**I-M. Roles of Planning Board and Planner**

- a. Pursuant to 76-1-106 and 76-1-107, MCA, the Planning Board serves in an advisory capacity to the governing body. Its duties include advising the governing body on all matters pertaining to the review of subdivisions and plats.
- b. Pursuant to 76-1-306, MCA, the planner (“Subdivision Administrator”), performs ministerial acts, such as providing technical assistance, to the Planning Board and the governing body on subdivision matters.

**I-N. Compliance**

After a subdivision is approved, the governing body or its designated agent(s) or agency may conduct periodic field inspections to verify that the conditions of subdivision approval are being met. Landowners or their representatives will be notified in advance of any such field inspections, and inspections will be carried out at a reasonable time.

DRAFT

## II. GENERAL PROCEDURES

---

*\*The provisions of this section apply to Sections III, IV, V, VI, VII, VIII and IX of these regulations.*

### **II-A. Subdivision - Preliminary Plats**

#### **II-A-1. Pre-application Process**

- a. Prior to submitting a subdivision application, the subdivider shall request a pre-application meeting with the planner. The meeting shall occur within 30 days after the subdivider submits a written request for the meeting to the planner. [Section 76-3-504(1)(q)(i) and (iv), MCA]
- b. At the time of the pre-application meeting request, the subdivider shall provide the planner a sketch of the proposed subdivision showing the layout of the proposed features in relation to existing site conditions. It is recommended the representative and the developer or landowner attend the pre-application meeting to avoid potential problems.
- i. The sketch may be a freehand sketch drawn directly on a print of a topographic map of the area proposed for division at a scale of 1 inch to 400 feet or larger that is adequate to show the property and must include the following:

*Information on the status of the site, including:*

1. location;
2. approximate tract and lot boundaries of existing tracts of record;
3. description of general terrain;
4. natural features on the land, including water bodies, floodplains geologic hazards, and soil types;
5. existing structures and improvements;
6. existing utility lines and facilities serving the area to be subdivided; and
7. existing easements and rights of way.

*Documentation on the status of the site, including:*

8. ownership information, such as a deed, option to buy or buy-sell agreement, including permission to subdivide;
9. water rights, including location of Agricultural Water User Facilities;
10. any special improvement districts; and
11. rights of first refusal for the property

ii. Information on the proposed subdivision, including:

1. tract and proposed lot boundaries;
2. proposed public and private improvements;
3. location of utility lines and facilities;
4. easements and rights of way;
5. parks and open space and proposed conservation easements;
6. existing zoning or development regulation standards;
7. existing conservation easements; and
8. existing covenants or deed restrictions.

c. At the pre-application meeting:

- i. the planner shall identify, for informational purposes, the state laws, local regulations, and growth policy provisions that may apply to the subdivision review process including but not limited to zoning regulations and floodplain regulations; [Section 76-3-504(1)(q)(ii), MCA].
- ii. the planner shall provide information on phasing, if applicable;
- iii. the planner shall provide the subdivider with a list of public utilities, local, state, and federal agencies, and any other entities that have an interest in the proposed subdivision and that may be contacted for comment by the planner or Planning Board on the subdivision application. The planner shall also identify the timeframes that the public utilities, agencies, and other entities are given to respond; and [Section 76-3-504(1)(q)(iii), MCA].
- iv. the planner may identify additional information that may be required for review of the subdivision application. This does not limit the ability of the planner to request additional information after an application has been submitted.

d. Unless the subdivider submits a subdivision application within 6 months of this pre-application meeting, the subdivider must request a new pre-application meeting prior to submitting the subdivision application. [Section 76-3-504(1)(q)(v), MCA]

e. Madison County provides that a subdivision pre-application may be reviewed by the Madison County Planning Board, at the request of the applicant or planner.

## **II-A-2. Subdivision Application and Preliminary Plat Submittal**

- a. The subdivider shall provide the required copies of the preliminary plat and supplement materials as determined by the planner. All preliminary plats shall be 24 inch by 36-inch size, 18 inch by 24 inch in size and/or 11 inch by 17-inch size as specified by the planner. The required copies of all supplemental materials shall be organized with a cover sheet, table of contents identifying all the elements, identification tabs for each element listed below and shall be bound in a three-

ring binder for each set and ready for distribution. The subdivider shall also provide the planner with an electronic form (PDF format) of all materials. Additionally, all supplementary studies must have been prepared/completed within one year prior to preliminary plat application submittal.

The subdivider shall submit to the Planning Department a subdivision application addressing these topics and containing the following materials, all described in more detail or on forms provided by the planner, as determined by the planner: [See Sections 76-3-504(1), MCA]

1. A completed and signed Subdivision Application Form; [Section 76-3-601(1), MCA]
2. The required review fee; [Section 76-3-602, MCA].
3. A preliminary plat (and if applicable a preliminary site plan); [Section 76-3-601(1), MCA]
4. A copy of the most current certificate of survey or subdivision plat pertaining to the subject parcel to be subdivided; [Section 76-3-103(9), MCA]
5. A map showing the location of the nearest utilities; [Section 76-3-504(1)(g)(iv), MCA]
6. A topographic map; [Section 76-3-504(1)(e), MCA]
7. A Stormwater Drainage Plan developed by Professional Engineer; [Section 76-3-504(1)(g)(ii), MCA]
8. If development is planned in phases, a phasing plan meeting the requirements of Section IV-A-2; [Section 76-3-617, MCA]
9. Subdivision guaranty dated no more than six months prior to the date of Preliminary Plat submittal; [Section 76-3-102(8), MCA]
10. Lienholder's acknowledgement of the proposed subdivision;
11. Documentation of legal and physical access; [Section 76-3-608(3)(d), MCA]
12. Documentation of existing easements, including those for Agricultural Water User Facilities; [Section 76-3-504(1)(k) and (l), MCA]
13. Existing covenants and deed restrictions; [Section 76-3-102(8), MCA]
14. Proposed covenants for the subdivision; [Section 76-3-102(8), MCA]
15. Existing water rights; [Section 76-3-504(1)(j), MCA]
16. Existing mineral rights; [Section 76-3-102(8), MCA]
17. Names and addresses of all adjoining property owners, including purchasers under contracts for deed; [Section 76-3-605(3), MCA]
18. Proposed road plans and profiles, including the location and dimensions of the roads, developed by a Professional Engineer. [Section 76-3-504(1)(g)(i), MCA]
19. Approach/access/encroachment permits submitted to the Montana Department of Transportation or the local jurisdiction; [Section 76-3-501(1)(d), (f) and (h), MCA]
20. Proposed easements, including the location of nearest utilities; [Section 76-3-504(1)(g)(iv) and (m), MCA]
21. Proposed disposition of water rights; [Section 76-3-504(1)(j), MCA]
22. Proposed disposition of mineral rights; [Section 76-3-102(8), MCA]
23. Parkland dedication calculations, location of and description of proposed parkland, or proposal for cash-in-lieu; [Section 76-3-621, MCA]
24. Environmental assessment for major subdivisions; [Section 76-3-603, MCA]
25. Summary of probable impacts for minor and major subdivisions; [Section 76-3-603(1)(a)(ii) and (b), MCA]
26. Transportation impact analysis or traffic study developed by a professional engineer (if identified during the pre-application meeting); [Section 76-3-501(1)(d), (f) and (h), MCA]
27. Noxious Weed Management Compliance Plan; [Section 7-22-2152, MCA]
28. Narrative identifying the floodplain status of the subject property; [76-3-504(1)(f), MCA]

29. Required water and sanitation information; [Section 76-3-622, MCA]
30. If applicable, will-serve letter from a municipal water and sewer service or by a county water and/or sewer district created under 7-13-2203 that supplies both water and sewer services; [Sections 76-3-609(6)]
31. Letter requesting a revocation of agricultural covenants; [Sections 76-3-207(1)(c) and 76-3-211, MCA]
32. Letter indicating locations of cultural or historic resources; [Section 76-3-621(7), MCA]
33. Land Stewardship Plan; [Section 76-3-608, MCA]
34. Variance request; [Section 76-3-506, MCA]
35. If applicable, analysis and identification of the Base Flood Elevation (BFE) on the property developed by a professional engineer (if identified during the preapplication meeting); [Section 76-3-504(1)(f), MCA]
36. Letter identifying and proposing mitigation for potential hazards or other adverse impacts as identified in the pre-application meeting and not covered by any of the above required materials; [Section 76-3-504(1)(e), MCA]
37. If proposing a minor subdivision, a copy of each instrument of transfer for the parcel or tract pertaining to the subject parcel filed or recorded since October 1, 2003. The instruments of transfer include but not limited to deed(s), certificate of survey(s) or subdivision plat(s); and [Section 76-3-609(2), MCA]
38. Such additional relevant and reasonable information as identified by the planner that is pertinent to the required elements of this section.

### **II-A-3. Preliminary Plat Review Process**

For both minor and major subdivisions, the initial review process is as follows:

#### **a. Element Review** [Section 76-3-604(1)(b) and (3), MCA]

- i. Within 5 working days of receipt of a subdivision application and fee, the planner shall determine whether the application contains all the applicable materials required by Section II-A-2 and shall give written notice to the subdivider of the planner's determination.

If the planner determines that elements are missing from the application, the planner shall identify those elements in the notification and take no further action until all the missing elements have been submitted.

The subdivider shall submit additional information to correct the deficiencies. The additional materials must be submitted in the form of one paper copy and one electronic copy.

If the subdivider submits additional information to correct the deficiencies, the planner shall have 5 working days to notify the subdivider whether the application contains all the materials required by Section II-A-2 Subdivision Application and Preliminary Plat Submittal as applicable.

If the applicant does not submit information to correct the deficiencies within 180 days following the planner's letter identifying the missing elements, the application and file will be terminated. The planner shall notify the applicant 30 days prior to the application being terminated.

This process shall be repeated until the subdivider submits an application containing all the materials required by Section II-A-2, or the application is terminated or withdrawn.

b. **Sufficiency Review** [Section 76-3-604(2) and (3), MCA]

- i. Within 15 working days after the planner notifies the subdivider that the application contains all of the required elements as provided in Subsection (a) above, the planner shall determine whether the application and required elements contain detailed, supporting information that is sufficient to allow for the review of the proposed subdivision under these regulations and shall give written notification to the subdivider of the planner's determination.

If the planner determines that the information in the application is not sufficient to allow for review of the proposed subdivision, the planner shall identify specific required information in its notification and no further action shall be taken on the application by the planner until all the materials identified as insufficient are submitted.

The subdivider shall submit additional information to address the insufficient items. The additional materials must be submitted in the form of one paper copy and one electronic copy.

If the subdivider submits additional information to correct the deficiencies in accordance with Subsection (i)(B) above, the planner shall have 15 working days to notify the subdivider whether the submitted information and required elements contain detailed, supporting information that is sufficient to allow for review of the proposed subdivision under these regulations.

If the applicant does not submit information to correct the deficiencies within 180 days following the planner's letter identifying the insufficient items, the application and file will be terminated. The planner shall notify the applicant 30 days prior to the application being terminated.

This process shall be repeated until the application contains detailed, supporting information that is sufficient for review of the proposed subdivision under the provisions of these regulations, or the application is terminated or withdrawn.

- ii. A determination that an application contains sufficient information for review as provided in this Subsection (b) does not ensure that the proposed subdivision will be approved or conditionally approved by the governing body and does not limit the ability of the planner, Planning Board, or the governing body to request additional information during the review process. If the planner, Planning Board, or the governing body determine there is not sufficient information to move forward with the review of the subdivision, they shall notify the subdivider of the insufficient information and the subdivision application shall be reviewed again for sufficiency when the information is submitted pursuant to this section. All review periods are suspended until the subdivision application is determined to be sufficient to proceed.

- iii. A determination of sufficiency by the planner pursuant to this subsection does not limit the DEQ from requiring additional water and sanitation information as part of the DEQ review of water and sanitation information.

**c. Major, Minor and First Minor Subdivision Review**

Following sufficiency review, next steps are determined based on the type of subdivision application (please see Sections III, IV and V).

**d. Applicable Regulations**

Subdivision review and approval, conditional approval or denial shall be based on those regulations in effect at the time a subdivision application and preliminary plat is deemed to contain sufficient information for review. If regulations change during the element or sufficiency review, the determination of whether the application contains the required elements and sufficient information, and the subdivision review, shall be based on the new regulations. [Section 76-3-604(9), MCA]

**II-A-4. Amended Applications**

- a. If the subdivider changes the subdivision application or preliminary plat before the public hearing for major subdivisions, or before the governing body makes its decision for minor subdivisions, the subdivider shall submit the amended application or preliminary plat to the planner for review.
  - i. Within 5 working days of receiving the amended application or preliminary plat, the planner shall determine whether the changes to the subdivision application or preliminary plat are material, as determined in Subsection (c) below.
  - ii. The applicable review period is suspended while the planner considers the amended application or preliminary plat.
  - iii. If the planner determines the changes are not material, the applicable review period resumes when the planner mails notice of the decision to the subdivider.
  - iv. If the planner determines the changes are material, the planner shall either require the subdivider to schedule a new pre-application meeting and resubmit the application and preliminary plat as a new subdivision application or proceed with the applicable review period upon certification from the planner that the application is sufficient for review.
- b. By making changes to a pending subdivision application or preliminary plat, the subdivider consents to suspension of the review period as provided above in Subsection (a)(ii).
- c. The following changes, although not an exhaustive list, may be considered material:
  - i. configuration or number of lots;
  - ii. road layout;
  - iii. configuration of park land or open spaces;
  - iv. easement provisions;

- v. designated access; or
  - vi. changes to the proposed use of the lots.
- d. A subdivider whose subdivision application or preliminary plat has been deemed materially changed by the planner may appeal the planner's decision to the governing body. The subdivider may request a public meeting with the governing body for first minor subdivision, or a public hearing with the governing body for major subdivisions and may submit additional evidence to show that the changes to the preliminary plat are not material.
- i. The applicable review period is suspended until the governing body's decision on the appeal is made.
  - ii. If the governing body concludes that the evidence and information demonstrate that the changes to the subdivision application or preliminary plat are material, the governing body shall require the subdivision application and preliminary plat to be resubmitted pursuant to Subsection (a)(iv) above.
  - iii. If the governing body concludes that the evidence and information demonstrate that the changes to the subdivision application or preliminary plat are not material, the applicable review period resumes as of the date of the decision.
  - iv. By appealing the decision of the planner, the subdivider agrees to suspension of the applicable review period provided in Subsection (d)(i).

#### **II-A-5. Amending Approved Preliminary Plats Before Final Plat Approval**

- a. If the subdivider proposes to change the preliminary plat after the preliminary plat approval but before the final plat approval, the subdivider shall submit the proposed changes to the planner for review.
  - i. Within five (5) working days of receiving the proposed changes, the planner shall determine whether the changes to the preliminary plat are material pursuant to Subsection (b) below.
  - ii. If the planner determines the changes are material, the planner may either require a public hearing with the applicable body for major subdivisions, or a meeting with the governing body for minor subdivisions, or, if the changes are extensive, the planner may require the subdivider to begin the subdivision review process again, starting with the pre-application meeting, and require payment of a new application fee.
  - iii. If the planner determines the changes are not material, the planner shall accept the changes, notify the subdivider and the governing body of that decision, and the governing body shall approve those changes in a meeting for which notice has been given of non-material changes to the preliminary plat.
- b. The following changes, although not an exhaustive list, may be considered material:
  - i. configuration or number of lots;

- ii. road layout;
  - iii. configuration of park land or open spaces;
  - iv. easement provisions;
  - v. designated access;
  - vi. changes to the proposed use of the lots; or
  - vii. changes to conditions of approval.
- c. A subdivider whose proposed changes to the preliminary plat have been deemed material by the planner may appeal the planner's decision to the governing body by written notice within 10 working days. The subdivider may request a public meeting with the governing body and may submit additional evidence to show that the changes to the preliminary plat are not material.
- d. If the subdivider and planner determine that a condition of approval is illegal or impossible to comply with due to circumstances outside the subdivider's control, economic hardship notwithstanding, the condition may be reviewed by the governing body through a properly noticed public hearing for major subdivisions, or a public meeting with the governing body for minors, to determine if the condition may be waived or amended.

#### **II-A-6. Extension of Preliminary Plat Approval Period [Section 76-3-610, MCA]**

- a. At the end of the preliminary plat approval period the governing body may grant an extension according to the following:
- i. The extension request is made by the subdivider in writing at least one month prior to the expiration of the preliminary plat.
  - ii. All requests for extensions must be in writing and must provide responses to the following criteria and supporting documentation, if any:
    - 1. Progress to date in completing or demonstration and evidence of good faith efforts to satisfy the required conditions of preliminary plat approval.
    - 2. Duration of the required extension and the ability of the subdivider to meet the required conditions of preliminary plat approval within the requested extension period.
    - 3. Significant changes in the vicinity of the subdivision that have occurred or are planned to occur within the requested extension period and whether the preliminary plat conditions adequately mitigate the significant changes. Significant changes constitute changes that may render the subdivision non-compliant with current design standards, such as road design, wildfire, or flood standards.
    - 4. Consistency with adopted comprehensive planning documents, including but not limited to, the jurisdiction's growth policy, annexation policy, capital improvements plan, transportation plan, etc.

5. Impacts to public health, safety, and general welfare.
  6. Planning and provisions of public facilities and services in the vicinity of the subdivision and whether the requested extension conforms to those plans and provisions.
- iii. A public hearing must be held with notice published in accordance with Section 76-3-605(3), MCA.
  - iv. Any mutually agreed-upon extension must be in writing and dated and signed by the members of the governing body and the subdivider or subdivider's agent.
- b. The governing body may issue more than one extension.

## **II-B. Final Plats** [Section 76-3-611, MCA]

### **II-B-1. Final Plat Contents**

The final plat submitted for approval must conform to the preliminary plat as previously reviewed and approved by the governing body and must incorporate all required modifications and comply with all conditions imposed at the time of subdivision application and preliminary plat approval. The final plat and accompanying documents must comply with the Montana Uniform Standards for Final Subdivision Plats 24.183.1107, ARM (provided in Appendix 1).

### **II-B-2. Final Plat Initial Review**

#### **a. Final Plat Submittal**

A final plat is considered to be received on the date of delivery to the governing body or the agent or agency designated by the governing body when accompanied by the review fee submitted as provided in Section 76-3-602 MCA. The final plat approval application form, which can be obtained from the planner, and all supplementary documents must be submitted to the planner at least 60 working days prior to the expiration of preliminary plat approval to accommodate for review time according to Subsection II-B-2 (b) and Section II-B-5 of these regulations. The submittal shall include, as applicable:

- i. A complete final plat application and final plat meeting the requirements of the Uniform Standards for Final Subdivisions Plats set forth in Appendix A;
- ii. the final plat review fee;
- iii. a written statement and full documentation from the applicant or their representative outlining how each condition of approval has been satisfied;

#### **b. Review by Planner/Subdivision Administrator**

- i. Within 20 working days of receipt of a final plat, the planner shall determine whether the final plat contains the information required in Subsection II-B-2 (a) and shall notify the subdivider or, with the subdivider's written permission, the subdivider's agent of that determination in

writing. If the planner determines that the final plat does not contain the information required under subsections, the planner shall identify the final plat's defects in the notification.

The planner may review subsequent submissions of the final plat only for information found to be deficient during the original review of the final plat under Subsection II-B-2 (b)(i).

The time limits, provided in Subsection II-B-2 (b)(i), apply to each submission of the final plat until a written determination is made that the final plat contains the information required under Subsection II-B-2 (a). and the subdivider or the subdivider's agent is notified.

Final plat applications will not be considered complete by the planner and will not be scheduled with the governing body until materials demonstrating that all conditions of preliminary approval have been satisfied are submitted.

- ii. If the planner determines the final plat differs materially from the approved or conditionally approved preliminary plat, the applicant shall be required to submit the amendments pursuant to Section II-A-5. The subdivider may appeal the planner's decision according to the procedures in Subsection II-A-5 (d).
- iii. The planner shall require that final subdivision plats be reviewed for errors and omissions in calculation or drafting by an examining land surveyor before recording with the County Clerk and Recorder. When the survey data shown on the plat meets the conditions pursuant to these regulations, the examining surveyor shall certify the compliance in a printed or stamped signed certificate on the plat.
- iv. The planner may forward the application to the County Attorney or Road Supervisor, requesting their review. Any comments received shall be included in the planner's report to the governing body.
- v. Time periods for final plat review can be extended by mutual agreement in writing.

### **II-B-3. Subdivision Improvements Agreement: Guaranty**

- a. As a condition of approval of the final plat, the subdivider must have installed all required improvements or have entered into a subdivision improvements agreement guaranteeing the construction, installation, and maintenance of all required improvements [Section 76-3-507, MCA]. The governing body may require up to 100% completion of improvements related to public health and safety, such as roads, firefighting facilities, and installation of utilities, before agreeing to the use of a subdivision improvements agreement. If 100% completion is required, engineering plans must be filed before approval of the final plat. A model subdivision improvements agreement and alternative methods of guaranteeing required improvements, the procedures, and requirements for securing an agreement, and suggested conditions for maintenance are available from the planner.
- b. **Security Guaranty**
  - i. If the subdivider chooses to enter into a subdivision improvements agreement, the subdivider shall submit estimated costs prepared by a professional engineer licensed in the State of

Montana for completing the required improvements. The amount of the guaranty shall be 125 percent (125%) of the estimated cost.

- ii. The subdivider shall provide a monetary security guaranty for 125 percent (125%) of the required improvements. Acceptable forms of guarantees are:
  1. Irrevocable Letter of Credit from a financial institution or other reputable institution subject to the approval of the governing body or designee;
  2. A Surety Performance Bond to guarantee the funds to complete improvements, subject to any requirements of the bonding company. The bond shall be payable to the governing body and shall remain in effect until the improvements have been completed and accepted by the governing body; or
  3. An Escrow Account where the subdivider has deposited cash, or collateral readily convertible to cash at face value either with the governing body or in escrow with a bank. The subdivider shall give the governing body an agreement with the bank guaranteeing the following:
    - a) That the funds in the escrow account are to be held in trust until released by the governing body and may not be used or pledged by the subdivider as security for any obligation during that period;
    - b) Should the subdivider fail to complete the required improvements, the bank shall immediately make the funds in escrow available to the governing body for completing these improvements.

**c. Reduction and Release of Guaranty**

- i. Upon completion of the required improvements, the subdivider shall submit to the governing body a statement certifying that:
  1. All required improvements are complete.
  2. All required improvements follow the minimum standards specified by the governing body for their construction if the governing body has standards. If standards do not exist, the governing body may require improvements following design plans prepared by a professional engineer licensed in the State of Montana.
  3. The developer knows of no defects in those improvements.
  4. That these improvements are free and clear of any encumbrances or liens.
  5. All applicable fees and surcharges have been paid.
- ii. In those cases where some improvement guarantees have been made in Subsection II-B-4 (b) above, the amount of the guaranty may be reduced upon installation and acceptance by the governing body of the required improvements. The amount of reduction shall correspond

to 90 percent (90%) of the value of the completed improvements. The reduction cannot include the value of improvements that have not been completed.

- iii. Upon completion of all the required improvements and certification of the items in Subsection II-B-4 (c). above, the governing body shall authorize the release of any remaining portion of the improvement guaranty.

#### **II-B-4. Final Plat Approval**

##### **a. Approval by the Governing Body**

The governing body shall examine every final subdivision plat. If a determination is made under Subsection II-B-2 (b). that the final plat contains the information required under Subsection II-B-2 (a) the governing body shall review and approve or deny the final plat within 20 working days.

The governing body shall approve it if it conforms to the conditions of preliminary plat approval and to the terms of the MSPA and these regulations or deny it pursuant to Subsection (ii) below.

- i. If the final plat is approved, the governing body shall certify its approval on the face of the final plat. When applicable, a certificate of the governing body expressly accepting any dedicated land, easements, or improvements will be filed with the final plat.
- ii. If the final plat is denied, the governing body shall write a letter stating the reason for denial and forward a copy to the subdivider within 10 working days. The governing body will return the final plat to the subdivider within 10 working days of the action. The subdivider may then make any necessary corrections and resubmit the final plat for approval.

Time periods for final plat review can be extended by mutual agreement in writing.

##### **b. Inaccurate Information**

The governing body may withdraw approval of a final plat if it determines that material information by the subdivider is inaccurate.

#### **II-B-5. Final Plat Filing**

After it is approved, the final plat may not be altered in any manner except as provided in Section II-B-7 below. The County Clerk and Recorder may not accept any plat for filing that does not bear the governing body's approval in proper form or that has been altered. The County Clerk and Recorder may file an approved plat only if it is accompanied by the documents specified in the Montana Uniform Standards for Monumentation (24.183.1101, ARM), and Final Subdivision Plats (24.183.1107, ARM), contained in Appendix A.

#### **II-B-6. Amending Recorded Plats**

Changes that materially alter any portion of a filed plat, its land divisions, or improvements, must be made by filing an amended plat showing all alterations.

### **a. Amended Plat Review**

- i. Any alteration which increases the number of lots or modifies six or more lots within a platted subdivision, abandons or alters a public road right-of-way or parkland dedication, or modifies a platted building envelope shall undergo subdivision review in accordance with these regulations.
- ii. A proposal for other changes to a filed final plat (e.g. increased number of lots or redesign or rearrangement of six or more lots but no increase in development density, or changes to land uses, etc) will be reviewed by the governing body, which has the discretion to determine whether the proposed changes constitute a material alteration to the original plat. If the changes constitute a material alteration, the governing body may require the amended plat request to undergo subdivision review in accordance with these regulations. If the changes do not constitute a material alteration, as determined by the governing body, an amended plat exemption will apply.

### **b. Amended Plat Exemption**

- i. Pursuant to 76-3-207(1)(d) and (e), MCA, the following plat amendments are exempt from review as a subdivision and shall not require governing body approval:
  1. For five (5) or fewer lots, the relocation of common boundaries;
  2. For five (5) or fewer lots, the aggregation of lots;
  3. Divisions made for the purpose of relocating a common boundary line between a single lot within a platted subdivision and adjoining land outside a platted subdivision (a restriction or requirement on the original platted lot or original unplatted parcel continues to apply to those areas).

c. An amended plat that must be reviewed by the governing body is subject to the procedures for reviewing major or minor subdivisions, as appropriate. The governing body may not approve an amended final plat without the written consent of the owners and lienholders of all lots in the subdivision which are affected or modified by the proposed amendment. The governing body may not approve an amendment that will place a lot in non-conformance with the standards contained in Section VI of these regulations unless the governing body holds a public hearing on the amendment and issues a written variance from the standards pursuant to Section I-J, Variances. The final amended plat submitted for approval must comply with the requirements for final subdivision plats under the Uniform Standards for Final Subdivision Plats (refer to 24.183.1107, ARM in Appendix A).

## **II-B-7. Correction of Recorded Plat**

### **a. Correction of Recorded Plat by Governing Body**

Pursuant to 76-3-614, MCA, when a recorded plat does not definitely show the location or size of lots or blocks or the location or width of any street or alley, the governing body may at its own expense cause a new and correct survey and plat to be made and recorded in the office of the Madison County Clerk and Recorder. The corrected plat must, to the extent possible, follow the plan

of the original survey and plat. The surveyor making the resurvey shall endorse the corrected plat referring to the original plat and noting the defect existing therein and the corrections made.

**b. Correction of Recorded Plat by Landowner**

A landowner or landowner’s representative may submit a corrected final plat to the governing body for review and approval. Eligible correction(s) are only those drafting or surveying errors that, in the judgment of the governing body, do not materially alter the plat. The plat shall be entitled, “Corrected Plat of the (name of subdivision) Subdivision”. The surveyor issuing the corrected plat shall endorse its face, refer to the original plat, note the defect existing therein, and explain the correction(s) made on the face of the new plat.

**c. Filing of Corrected Plats**

Once the governing body has reviewed and approved a corrected plat, it may be filed with the Clerk and Recorder.

**II-B-8. Vacation of Recorded Plat**

Pursuant to 76-3-305, MCA, any recorded plat may be vacated either in whole or in part, as provided by 7-5-2501, 7-5-2502, 7-14-2616(1) and (2), 7-14-2617, 7- 14-4114(1) and (2), and 7-14-4115, MCA. Upon vacation, the governing body or the district court, as provided in 7-5-2502, MCA, shall determine to which properties the title to the streets and alleys of the vacated portions must revert.

The governing body or the district court, as provided in 7-5-2502, MCA, shall take into consideration the previous platting; the manner in which the right-of-way was originally dedicated, granted, or conveyed; the reasons stated in the petition requesting the vacation; the parties requesting the vacation; and any agreements between the adjacent property owners regarding the use of the vacated area.

The title to the streets and alleys of the vacated portions may revert to one or more of the owners of the properties within the platted area adjacent to the vacated portions.

However, when any pole line, pipeline, or any other public or private facility is located in a vacated street or alley at the time of the reversion of the title to the vacated street or alley, the owner of the public or private utility facility has an easement over the vacated land to continue the operation and maintenance of the public utility facility.

# III. REVIEW AND APPROVAL PROCEDURES FOR MINOR SUBDIVISIONS

---

## III-A. First Minor Subdivisions

If the tract of record proposed to be subdivided has not been subdivided or created by a subdivision or has not resulted from a tract of record that has had more than five parcels created from that tract of record under Section 76-3-201 or 76-3-207, MCA since October 1, 2003, then the proposed subdivision is a first minor subdivision. [Section 76-3-609, MCA]

### III-A-1. **First Minor Subdivision Review**

The pre-application process and initial review process set forth in Section II, General Procedures, apply to this section.

### III-A-2. **First Minor Subdivision Application and Preliminary Plat Submittal**

The subdivider shall submit to the planner a subdivision application containing the materials identified in Section II-A-2 and in the pre-application meeting.

### III-A-3. **First Minor Subdivision Exceptions** [Section 76-3-609(2)(d) and (e), MCA]

The following do not apply to first minor subdivisions:

- a. preparation of an environmental assessment;
- b. public hearing requirements; and
- c. parkland dedication.

### III-A-4. **First Minor Subdivision Review Process**

- a. **Time Period for Approval, Conditional Approval, or Denial** [Section 76-3-609(2)(a) and (b), MCA].

Within 35 working days of receiving a complete and sufficient application, the governing body shall approve, conditionally approve, or deny the proposed subdivision according to Section III-A-8 of these regulations, unless the subdivider and the planner agree to an extension or suspension of the review period, not to exceed one year.

- b. **Public Agency and Utility Review** [Section 76-3-504(1)(i) and (1)(q)(iii), MCA]

Review and comment by public agencies or utilities may not delay the governing body's action on the subdivision application beyond the 35-working day review period. The governing body will make these comments available to the subdivider and to the public upon request. If, during the review of the application, the planner contacts a public utility, agency, or other entity that was not included on the list provided during the pre-application meeting, the planner shall notify the subdivider of the contact and the timeframe for response.

**c. Allowed Actions and Uses on a Subdivision Lot** [Section 76-3-501(2), MCA]

Any action or land use that is not specifically prohibited in the conditions of subdivision approval required by the governing body are specifically allowed unless otherwise subject to additional restrictions that may be provided in the County's subdivision and applicable zoning regulations.

**d. Enforcement and Interpretation of Conditions of Approval** [Section 76-3-501(3), MCA]

If the County has historically interpreted and enforced or chosen not to enforce a condition of subdivision approval that has benefited a property owner, the County may not undertake a different interpretation or enforcement action against a similarly situated property owner located within the same subdivision.

**e. Specific, Documentable and Defined Purpose or Objective for Conditions of Approval** [76-3-620(2), MCA]

If the governing body conditionally approves the proposed subdivision, each condition required for subdivision approval must identify a specific, documentable, and clearly defined purpose or objective related to the primary criteria set forth in the review criteria found in 76-3-608(3) MCA and pursuant to Section III-A-7 that form the basis for the conditions of approval.

**f. Covenants and Homeowners Association Documents - Review and Approval** [Section 76-3-604(10)]

Unless otherwise provided by law, the governing body may review but does not have approval authority of the governing documents (covenants and homeowners association articles of incorporation) of the subdivision or amendments of these documents unless they directly and materially impact a condition of subdivision approval for the subdivision.

**g. Fees and Real Property Dedications for Housing** [Section 76-3-514, MCA]

The governing body may not require, as a condition for approval of a subdivision:

- i. the payment of a fee for the purpose of providing housing for specified income levels or at specified sale prices; or
- ii. the dedication of real property for the purpose of providing housing for specified income levels or at specified sale prices.

**h. Set Aside or Monetary Contribution for Agricultural Soils** [Section 76-3-608(4), MCA]

The governing body cannot require a set-aside of land or monetary contribution for the loss of agricultural soils under 76-3-608 MCA.

### **III-A-5. First Minor Planning Board Recommendation and Governing Body Consideration and Decision**

The Planning Board consideration of the subdivision is the same process as followed by the governing body. The Planning Board makes a recommendation to the governing body and the governing body, after doing its own analysis, makes the final decision.

#### **a. Prerequisites to Approval**

The Planning Board may not recommend, and the governing body may not approve or conditionally approve a subdivision application and preliminary plat unless the proposed subdivision: [Section 76-3-608(3)(b), MCA]

- i. provides easements for the location and installation of any planned utilities, both on and off site;
- ii. provides legal and physical access to each parcel within the subdivision and the notation of that access on the applicable plat and any instrument transferring the parcel;
- iii. assures that all required public or private improvements will be installed before final plat approval, or that their installation after final plat approval will be guaranteed as provided by Section II-B-4 of these regulations;
- iv. assures that the requirements of Section 76-3-504 (1)(j), MCA, regarding the disclosure and disposition of water rights as set forth in Section VI-O, of these regulations, have been considered and will be accomplished before the final plat is submitted; and
- v. assures that the requirements of Section 76-3-504 (1)(k) regarding watercourse and irrigation easements as set forth in Section VI-N have been considered and will be accomplished before the final plat is submitted.
- vi. For a proposed subdivision that will create one or more parcels containing less than 20 acres, the subdivider shall obtain approval by the DEQ as a condition of approval of the final plat. This approval applies to the development of lots at the time of the approval and is no guarantee that a source of water or a location for a septic system or drain fields will be available when the lots are developed.
- vii. For a proposed subdivision that will create one or more parcels containing 20 acres or more, the subdivider shall demonstrate in the preliminary plat application that there is an adequate water source and at least one area for a septic system and a replacement drain field for each lot. This information shall be submitted to the local reviewing authority to complete the sanitation review of parcels that do not fall under the review authority of DEQ. [Section 76-3-622, MCA].

#### **b. Consideration- Standards**

In recommending or granting approval, conditional approval or denial of the subdivision application and preliminary plat, the Planning Board or governing body shall base its

recommendation or decision on compliance of the subdivision application and preliminary plat with the following:

- i. these regulations, including but not limited to the standards set forth in Section VI Design and Improvements Standards;
- ii. applicable zoning regulations;
- iii. the MSPA, including but not limited to the following impacts under Section 76-3-608(3)(a) MCA:
  - impact on agriculture, excluding a consideration of the loss of agricultural soils;
  - impact on agricultural water user facilities;
  - impact on local services;
  - impact on the natural environment;
  - impact on wildlife;
  - wildlife habitat;
  - impact on public health and safety; and
  - Proposed mitigation for the identified impacts.
- iv. other applicable regulations such as, but not limited to, Airport Affect Area Regulations and Floodplain Regulations.

Refer to the “Definitions” section at the beginning of these regulations for definitions for each of the criteria listed above A through G.

**c. Consideration-Evidence**

As the basis for recommending or granting approval, conditional approval or denial of the subdivision application and preliminary plat, the Planning Board or governing body may consider, without limitation, the following (as applicable): [Section 76-3-608(1), MCA]

- i. the subdivision application and preliminary plat;
- ii. the summary of probable impacts and mitigation;
- iii. an officially adopted growth policy;
- iv. planner's staff report and recommendation;
- v. relevant agency and public comments; and

vi. any additional information authorized by law.

**d. Written Recommendation of the Planning Board**

Within ten (10) working days after the public meeting, the Planning Board shall submit the following, in writing, to the subdivider and the governing body:

- i. recommended findings of fact based upon 76-3-620, MCA and the evidence in subsection (a)(ii) above that discuss and consider the subdivision's compliance with and impact on the items listed in subsection (a)(i) of these regulations;
- ii. a recommendation for approval, conditional approval (including any recommended conditions and/or mitigation measures), or denial of the subdivision application and preliminary plat; and [Section 76-3-608(1), MCA]
- iii. a recommendation for approval or denial of any requested variances (See Section I-J). [Section 76-3-506, MCA]
- iv. the Planning Board or planner shall collect public comment regarding the water and sanitation information required by the MSPA and these regulations. The water and sanitation information required to be submitted is detailed in 76-3-622, MCA. The Planning Board shall forward all comments regarding water and sanitation to the governing body. [Section 76-3-604(7)(a), MCA]

**e. Documentation of Governing Body Decision**

- i. As the basis for its decision to approve, conditionally approve, or deny the proposed subdivision [Section 76-3-608(1), MCA] the governing body shall issue written findings of fact based upon 76-3-620, MCA that discuss and weigh the proposed subdivision's compliance with the above subsections, as well as the Planning Board's recommendation. Findings of fact by the governing body concerning whether the development of the proposed subdivision meets the requirements of these regulations must be based on the entire record. The governing body's findings of fact must be sustained unless they are arbitrary, capricious, or unlawful. [Section 76-3-608(10), MCA]
- ii. The governing body shall collect public comment on water and sanitation information and shall make any comments submitted, or a summary of the comments submitted, available to the subdivider within 30 days after conditional approval or approval of the subdivision application and preliminary plat. [Section 76-3-604(7)(a), MCA]
  1. The subdivider shall, as part of the subdivider's application for sanitation approval, forward the comments or the summary provided by the governing body to the: [Section 76-3-604(7)(b), MCA]
    - a) reviewing authority provided in, Title 76, chapter 4, MCA for subdivisions that will create one or more parcels containing less than 20 acres; or
    - b) the local reviewing authority for proposed subdivisions that will create one or more parcels containing 20 acres or more and less than 160 acres.

- iii. When the governing body approves, denies, or conditionally approves the proposed subdivision, it shall, within 30 working days following the oral decision, send the subdivider a letter, with the appropriate signature, and make the letter available to the public [Section 76-3-620, MCA]. The letter shall:
  1. Contain information regarding the appeal process for the denial or imposition of conditions;
  2. identify the regulations and statutes that are used in reaching the decision to approve, deny, or impose conditions and explain how they apply to the basis of the decision;
  3. provide the facts and conclusions that the governing body relied upon in making the decision and reference documents, testimony, or other materials that form the basis of the decision;
  4. identifies the conditions that apply to the preliminary plat approval and that must be satisfied before the final plat may be approved;
  5. each condition required for subdivision approval must identify a specific, documentable, and clearly defined purpose or objective related to the primary criteria set forth in the review criteria found in 76-3-608(3) MCA; and
  6. set forth the time limit for approval, pursuant to Subsection (f) below.

**f. Subdivision Application and Preliminary Plat Approval Period**

- i. Upon approval or conditional approval of the preliminary plat, the governing body shall provide the subdivider with a dated and signed statement of approval. The approval shall be in force for no more than three calendar years. [Section 76-3-610, MCA]

At least 30 days prior to the expiration of the preliminary plat approval, the governing body may, at the request of the subdivider, extend the approval for a mutually agreed-upon period of time. Any mutually agreed-upon extension must be in writing and dated and signed by the members of the governing body and the subdivider or the subdivider's agent. The governing body may issue more than one extension.

The governing body may extend the approval for more than one year if that approval period is included as a specific condition of a written subdivision improvements agreement between the governing body and the subdivider, provided for in Section II-B-4.

- ii. After the application and preliminary plat are approved, the governing body may not impose any additional conditions as a prerequisite to final plat approval unless the preliminary plat approval expires. [Section 76-3-610(2), MCA]
- iii. The governing body may withdraw approval or conditional approval of an application and preliminary plat if it determines that information provided by the subdivider, and upon which the approval or conditional approval was based, is inaccurate.

### **III-A-6. Amended Applications Prior to Governing Body Decision**

If the subdivider changes the subdivision application or preliminary plat after the planner determines that the application is sufficient pursuant to Section II-A-3 but before the governing body decision, the subdivider shall submit the amended application to the planner for review according to the procedures in Section II-A-4 Amended Applications.

### **III-A-7. Subdivider's Preference for Mitigation**

No later than two working days before the meeting at which the governing body is to consider the subdivision application and preliminary plat, the subdivider is encouraged to submit in writing to the planner the subdivider's comments on and responses to the planner's recommendations, as well as any proposed mitigation measures not already discussed with the planner. The governing body will consult with the subdivider and will give due weight and consideration to the subdivider's expressed preferences regarding mitigation [Section 76-3-608 (5)(b), MCA] and the mitigation approved by the governing body shall be consistent with the written findings of fact required under 76-3-620, MCA.

### **III-A-8. First Minor Subdivision Final Plat**

The final plat must include the contents and be submitted and reviewed in accordance with the appropriate requirements contained in Section II-B, Final Plats.

## **III-B. Subsequent Minor Subdivisions**

In accordance with Section 76-3-609 (4) MCA, the governing body may adopt subdivision regulations that establish requirements for review of subsequent minor subdivisions that meet or exceed the requirements that apply to the first minor subdivision.

Under these regulations, Madison County requires that all subsequent minor subdivisions be processed as major subdivisions.

## **III-C. Administrative Minor Subdivisions**

### **III-C-1. Criteria to Be Met**

First minor subdivisions must be reviewed using the administrative process provided for in III-C-2 if the proposed subdivision:

- a. is located in an area that is subject to and complies with zoning regulations adopted pursuant to Title 76, chapter 2, part 2 or 3, that, at a minimum, address development intensity through densities, bulk and dimensional requirements, and use standards;
- b. has a will-serve letter from a municipal water and sewer service or by a county water and/or sewer district created under 7-13-2203 that supplies both water and sewer services;
- c. has existing legal and physical access to each lot; and

- d. does not require a variance to any of the contents of the subdivision regulations required in 76-3-504(1)(g), MCA.

### **III-C-2. Exemptions for Administrative Minor Subdivision**

An administrative minor subdivision meeting the requirements of III-C-1 is exempt from:

- a. submitting the summary of probable impacts based on criteria described in 76-3-608(3) and the environmental assessment required in 76-3-603, MCA;
- b. the review criteria described in 76-3-608(3)(a), MCA; and
- c. the requirements of 76-3-209(2) through (5), MCA.

### **III-C-3. Planner Review**

For administrative minor subdivisions, the planner appointed by the governing body shall:

- a. assumes all decision-making authority of the governing body provided in 76-3-608, MCA;
- b. approve, conditionally approve, or deny an administrative minor subdivision and issue a written statement pursuant to 76-3-620, MCA within 30 working days of a determination by the reviewing agent or agency that the application contains required elements and sufficient information for review as provided in 76-3-604(1) through (3), MCA; and
- c. immediately on a determination that the application meets the requirements of 76-3-604(1) through (3), MCA, notify by first-class mail of the pending application:
  - i. each property owner of record whose property is immediately adjoining the land included in the preliminary plat; and
  - ii. each purchaser under contract for deed of property immediately adjoining the land included in the preliminary plat.

### **III-C-4. Objections to Planner Review**

If a party identified in 76-3-625(3), MCA objects to a planner's decision to approve, conditionally approve, or deny an administrative minor subdivision, the party may request in writing that the planner forward the application on to the governing body. The governing body shall sustain the planner's decision based on the record as a whole unless the decision was arbitrary, capricious, or unlawful. The governing body has 15 working days from the receipt of the request to review a decision to approve, conditionally approve, or deny the administrative minor subdivision and make a final determination.

### **III-C-5. Other Requirements**

All the requirements of Title 76, chapter 3, except those exempted in III-C-2 and III-C-3, apply to an administrative minor subdivision.

## **IV. REVIEW AND APPROVAL PROCEDURES FOR MAJOR SUBDIVISIONS**

---

### **IV-A. Review and Approval Procedures for Major Subdivisions**

The pre-application process and initial review process set forth in Section II, General Procedures, apply to this section.

#### **a. Public Agency and Utility Review [Section 76-3-504(1)(i) and (1)(q)(iii), MCA]**

Review and comment by public agencies or utilities may not delay the governing body's action on the subdivision application beyond the 60 or 80-working day review period. The governing body will make these comments available to the subdivider and to the public upon request. If, during the review of the application, the planner contacts a public utility, agency, or other entity that was not included on the list provided during the pre-application meeting, the planner shall notify the subdivider of the contact and the timeframe for response.

#### **b. Allowed Actions and Uses on a Subdivision Lot [Section 76-3-501(2), MCA]**

Any action or land use that is not specifically prohibited in the conditions of subdivision approval required by the governing body are specifically allowed unless otherwise subject to additional restrictions that may be provided in the County's subdivision and applicable zoning regulations.

#### **c. Enforcement and Interpretation of Conditions of Approval [Section 76-3-501(3), MCA]**

If the County has historically interpreted and enforced or chosen not to enforce a condition of subdivision approval that has benefited a property owner, the County may not undertake a different interpretation or enforcement action against a similarly situated property owner located within the same subdivision.

#### **d. Specific, Documentable and Defined Purpose or Objective for Conditions of Approval [76-3-620(2), MCA]**

If the governing body conditionally approves the proposed subdivision, each condition required for subdivision approval must identify a specific, documentable, and clearly defined purpose or objective related to the primary criteria set forth in the review criteria found in 76-3-608(3) MCA and pursuant to Section III-A-7 that form the basis for the conditions of approval.

#### **e. Covenants and Homeowners Association Documents - Review and Approval [Section 76-3-604(10)]**

Unless otherwise provided by law, the governing body may review but does not have approval authority of the governing documents (recorded covenants and homeowners association articles of incorporation) of the subdivision or amendments to these documents unless they directly and materially impact a condition of subdivision approval for the subdivision.

#### **f. Fees and Real Property Dedications for Housing [Section 76-3-514, MCA]**

The governing body may not require, as a condition for approval of a subdivision:

- i. the payment of a fee for the purpose of providing housing for specified income levels or at specified sale prices; or
- ii. the dedication of real property for the purpose of providing housing for specified income levels or at specified sale prices.

**g. Set Aside or Monetary Contribution for Agricultural Soil [Section 76-3-608(4), MCA]**

The governing body cannot require a set-aside of land or monetary contribution for the loss of agricultural soils under 76-3-608 MCA.

**IV-A-1. Subdivision Application and Preliminary Plat Submittal**

The subdivider shall submit to the governing body or to the agent or agency authorized by the governing body a subdivision application containing the materials identified in Section II-A-2 and in the pre-application meeting, including water and sanitation information required under Section 76-3-622, MCA. [Section 76-3-601(1), MCA]

**IV-A-2. Phased Subdivision and Preliminary Plat Submittals [Section 76-3-617, MCA]**

A subdivider applying for phased development review shall submit with the phased development application an overall phased development preliminary plat on which independent platted development phases must be presented. The phased development application must contain the information required pursuant to Section I through Section IV of these regulations for all phases of a development and a schedule for when the subdivider plans to submit for review each phase of the development.

The subdivider may change the schedule for review of each phase of the development upon approval of the governing body after a public hearing as provided below in Subsection (c) if the change does not negate conditions of approval or otherwise adversely affect public health, safety, and welfare.

- a. Except as otherwise provided by Section IV-A-2, the phased development application must be reviewed in conformity with Sections I through Section IV of these regulations. In addition, each phase of the phased development must be reviewed as provided below in Subsection (c) and (d).
- b. The governing body may approve phased developments that extend beyond the time limits set forth in these regulations in Subsection IV-A-2 (c) but all phases of the phased development must be submitted for review and approved, conditionally approved, or denied within 20 years of the date the overall phased development preliminary plat is approved by the governing body.
- c. For any phase of the approved subdivision submitted for final plat approval within 5 years after the date of preliminary approval of the subdivision, no further public hearing is required before submittal for final plat approval. Final plat approval shall be in accordance with Section II-B.

- d. For any phase of the approved subdivision submitted for final plat approval more than 5 years after the date of preliminary plat approval of the subdivision, the subdivider shall provide written notice to the governing body not more than 1 year or less than 90 calendar days in advance of submitting the final plat application and the governing body shall hold a public hearing pursuant to Section I-F within 30 working days after receipt of the written notice from the subdivider.
- e. At the public hearing set forth in IV-A-5-a. the governing body shall determine whether changed circumstances justify amending any conditions of approval. The governing body may amend or impose additional conditions of approval only if it determines, based on a review of the primary criteria, that the existing conditions of approval are inadequate to mitigate the potential significant adverse impacts during the original review based on changed circumstances.
- f. Notwithstanding the provisions of Section II-A, the governing body shall issue supplemental written findings of fact within 20 working days of the hearing.
- g. Any additional conditions must be met before final plat approval for each remaining phase and the approval in accordance with Section II-B is in force for not more than 3 calendar years or less than 1 calendar year within the maximum time frame provided above in Subsection (b).
- h. The governing body may impose a reasonable periodic fee for the review under Subsection (c), above, of the phases in the phased development.
- i. Modifications to an approved phased development prior to final plat approval shall be reviewed according to the procedures in Section II-A-5.
- j. The governing body may impose additional conditions prior to final plat approval of phased subdivision projects submitted more than five years after the date of preliminary plat approval. These additional conditions may include, but are not limited to, updated studies/reports

#### **IV-A-3. Time Period for Approval, Conditional Approval, or Denial**

##### **a. Governing Body Review**

Within 60 working days, or 80 working days for proposals containing 50 or more lots, the governing body shall approve, conditionally approve, or deny the proposed subdivision according to Section IV-A-8 of these regulations, unless the subdivider and the planner agree to an extension or suspension of the review period, or a subsequent public hearing is held pursuant to Section IV-A-7 of these regulations. The review period of 60 or 80 working days begins the day after the planner notifies the subdivider or the subdivider's agent in writing that the subdivision application is sufficient for review. [Section 76-3-604(4), MCA].

##### **IV-A-4. Amended Applications Prior to Public Hearing**

- a. If the subdivider changes the subdivision application or preliminary plat after the planner determines the application is sufficient pursuant to Section II-A-3 but before the Planning Board hearing, the subdivider shall submit the amended application to the planner for review according to the procedures in Section II-A-4 Amended Applications.

#### **IV-A-5. Planning Board Recommendation and Governing Body Consideration and Decision**

The Planning Board consideration of the subdivision is the same process as followed by the governing body. The Planning Board makes a recommendation to the governing body and the governing body, after doing its own analysis, makes the final decision.

##### **a. Public Hearing**

After the subdivision application is deemed to have all the required elements and contain detailed, supporting information that is sufficient to allow for review, and the planner has prepared a staff report, the Planning Board shall schedule and hold a public hearing on the subdivision application. If the governing body holds the public hearing, a regular Planning Board meeting with public comment on the subdivision application would be held prior. In some cases, multiple public hearings with the Planning Board and governing body may be held.

##### **b. Prerequisites to Approval**

The Planning Board may not recommend, and the governing body may not approve or conditionally approve a subdivision application and preliminary plat unless the proposed subdivision: [Section 76-3-608(3)(b), MCA]

- i. provides easements for the location and installation of any planned utilities, both on and off site;
- ii. provides legal and physical access to each parcel within the subdivision and the notation of that access on the applicable plat and any instrument transferring the parcel;
- iii. assures that all required public or private improvements will be installed before final plat approval, or that their installation after final plat approval will be guaranteed as provided by Section II-B-4 of these regulations;
- iv. assures that the requirements of Section 76-3-504 (1)(j), MCA, regarding the disclosure and disposition of water rights as set forth in Section VI-O, of these regulations, have been considered and will be accomplished before the final plat is submitted; and
- v. assures that the requirements of Section 76-3-504 (1)(k) regarding watercourse and irrigation easements as set forth in Section VI-N have been considered and will be accomplished before the final plat is submitted.
- vi. For a proposed subdivision that will create one or more parcels containing less than 20 acres, the subdivider shall obtain approval by the DEQ as a condition of approval of the final plat. This approval applies to the development of lots at the time of the approval and is no guarantee that a source of water or a location for a septic system or drain fields will be available when the lots are developed.
- vii. For a proposed subdivision that will create one or more parcels containing 20 acres or more, the subdivider shall demonstrate in the preliminary plat application that there is an adequate water source and at least one area for a septic system and a replacement drain field for each

lot. This information shall be submitted to the local reviewing authority to complete the sanitation review of parcels that do not fall under the review authority of DEQ. [Section 76-3-622, MCA]

viii. Provides for the appropriate park dedication or cash-in-lieu.

### c. **Consideration-Standards**

In recommending or granting approval, conditional approval or denial of the subdivision application and preliminary plat, the Planning Board or governing body shall base its recommendation or decision on compliance of the subdivision application and preliminary plat with the following:

- i. these regulations, including but not limited to the standards set forth in Section VI Design and Improvements Standards;
- ii. applicable zoning regulations;
- iii. the MSPA, including but not limited to the following impacts under Section 76-3-608(3)(a), MCA:
  - impact on agriculture, excluding a consideration of the loss of agricultural soils;
  - impact on agricultural water user facilities;
  - impact on local services;
  - impact on the natural environment;
  - impact on wildlife;
  - wildlife habitat;
  - impact on public health and safety; and
  - Proposed mitigation for the identified impacts.
- iv. other applicable regulations, such as, but not limited to Airport Affect Area Regulations, Waterbodies, and Floodplain Regulations.

Refer to the “Definitions” section at the beginning of these regulations for definitions for each of the criteria listed above.

### d. **Consideration-Evidence**

As the basis for recommending or granting approval, conditional approval or denial of the subdivision application and preliminary plat, the Planning Board or governing body may consider, without limitation, the following (as applicable): [Section 76-3-608(1), MCA]

- i. the subdivision application and preliminary plat;
- ii. the environmental assessment; [Section 76-3-603, MCA]
- iii. the summary of probable impacts and mitigation;
- iv. an officially adopted growth policy;
- v. planner's staff report and recommendation;
- vi. relevant agency and public comments; and
- vii. any additional information authorized by law.

**e. Written Recommendation of the Planning Board**

Within ten (10) working days after the public meeting, the Planning Board shall submit the following, in writing, to the subdivider and the governing body:

- i. recommended findings of fact based upon 76-3-620, MCA and the evidence in subsection (a)(ii) above that discuss and consider the subdivision's compliance with and impact on the items listed in subsection (a)(i) of these regulations;
- ii. a recommendation for approval, conditional approval (including any recommended conditions and/or mitigation measures), or denial of the subdivision application and preliminary plat; and [Section 76- 3-608(1), MCA]
- iii. a recommendation for approval or denial of any requested variances (See Section I-J). [Section 76-3-506, MCA]
- iv. The Planning Board or planner shall collect public comment regarding the water and sanitation information required by the MSPA and these regulations. The water and sanitation information required to be submitted is detailed in 76-3-622, MCA. The Planning Board shall forward all comments regarding water and sanitation to the governing body. [Section 76-3-604(7)(a), MCA]

**f. Documentation of Governing Body Decision**

- i. As the basis for its decision to approve, conditionally approve, or deny the proposed subdivision [Section 76-3-608(1), MCA] the governing body shall issue written findings of fact based upon 76-3-620, MCA that discuss and weigh the proposed subdivision's compliance with the above subsections as well as the Planning Board's recommendation. Findings of fact by the governing body concerning whether the development of the proposed subdivision meets the requirements of these regulations must be based on the entire record. The governing body's findings of fact must be sustained unless they are arbitrary, capricious, or unlawful. [Section 76-3-608(10), MCA]
- ii. The governing body shall collect public comment on water and sanitation information and shall make any comments submitted, or a summary of the comments submitted, available to

the subdivider within 30 days after conditional approval or approval of the subdivision application and preliminary plat. [Section 76-3-604(7)(a), MCA]

1. The subdivider shall, as part of the subdivider's application for sanitation approval, forward the comments or the summary provided by the governing body to the: [Section 73-3-604(7)(b), MCA]
  - a) reviewing authority provided in, Title 76, chapter 4, MCA for subdivisions that will create one or more parcels containing less than 20 acres; or
  - b) the local reviewing authority for proposed subdivisions that will create one or more parcels containing 20 acres or more and less than 160 acres.
- iii. When the governing body approves, denies, or conditionally approves the proposed subdivision, it shall within 30 working days following the oral decision send the subdivider a letter, with the appropriate signature, and make the letter available to the public [Section 76-3-620, MCA]. The letter shall:
  1. contain information regarding the appeal process for the denial or imposition of conditions;
  2. identify the regulations and statutes that are used in reaching the decision to approve, deny, or impose conditions and explain how they apply to the basis of the decision;
  3. provide the facts and conclusions that the governing body relied upon in making the decision and reference documents, testimony, or other materials that form the basis of the decision;
  4. identifies the conditions that apply to the preliminary plat approval and that must be satisfied before the final plat may be approved;
  5. each condition required for subdivision approval must identify a specific, documentable, and clearly defined purpose or objective related to the primary criteria set forth in the review criteria found in 76-3-608(3) MCA; and
  6. set forth the time limit for approval, pursuant to Subsection (f) below.

Notwithstanding the foregoing, the governing body may not consider any information regarding the subdivision application that is presented after the final public hearing (which may include a subsequent hearing if any) when making its decision to approve, conditionally approve, or deny the proposed subdivision.

**g. Subdivision Application and Preliminary Plat Approval Period**

- i. Upon approval or conditional approval of the preliminary plat, the governing body shall provide the subdivider with a dated and signed statement of approval. The approval shall be in force for no more than three calendar years. [Section 76-3-610, MCA]

At least 30 days prior to the expiration of the preliminary plat approval, the governing body may, at the request of the subdivider, extend the approval for a mutually agreed-upon period of time. Any mutual agreed-upon extension must be in writing (Appendix 17) and dated and signed by the members of the governing body and the subdivider or the subdivider's agent. The governing body may issue more than one extension.

The governing body may extend the approval for more than one year if that approval period is included as a specific condition of a written subdivision improvements agreement between the governing body and the subdivider, provided for in Section II-B-4.

- ii. After the application and preliminary plat are approved, the governing body may not impose any additional conditions as a prerequisite to final plat approval unless the preliminary plat approval expires. [Section 76-3-610(2), MCA]
- iii. The governing body may withdraw approval or conditional approval of an application and preliminary plat if it determines that information provided by the subdivider, and upon which the approval or conditional approval was based, updated planner's staff report and Planning Board recommendation; and

#### **IV-A-6. Subdivider's Preference for Mitigation**

No later than two working days before the meeting or hearing at which the governing body is to consider the subdivision application and preliminary plat, the subdivider is encouraged to submit in writing to the planner the subdivider's comments on and responses to the Planning Board's recommendations as well as any proposed mitigation measures not already discussed with the planning board. The governing body will consult with the subdivider and will give due weight and consideration to the subdivider's expressed preference regarding mitigation. [Section 76-3-608 (5)(b), MCA]

#### **IV-A-7. Amended Applications Following the Public Hearing**

If the subdivider changes the subdivision application or preliminary plat following the public hearing, the subdivider shall submit the amended application or preliminary plat to the planner for review pursuant to Section II-A-4 Amended Applications.

#### **IV-A-8. Governing Body Meeting – Consideration of New Information** [Section 76-3-615, MCA]

- a. If an amended application was not submitted to the planner following the public hearing, but relevant new information or substantial changes to the design of the subdivision is presented to the governing body following the Planning Board's public hearing regarding the proposed major subdivision, the governing body shall determine whether public comments or other information presented constitutes relevant, new information or a substantial change to the design of the subdivision that has a substantial effect on the governing body's consideration of the application and constitutes the need for a subsequent public hearing.
- b. If the governing body determines that the information presented constitutes the information described in subsection a. above, the governing body may:

- i. approve, conditionally approve, or deny the proposed subdivision without basing its decision on the new information if the governing body determines that the new information is either irrelevant or not credible or the change to the design of the subdivision does not substantially impact the analysis of potentially significant adverse impacts; or
- ii. schedule or direct its agent or agency to schedule a subsequent public hearing for consideration of only the new information including a substantial change to the design of the subdivision for purposes or considering its findings of fact and conclusions and any proposed conditions of approval in light of the new information that the governing body will rely on in making its decision on the proposed subdivision.

**IV-A-9. Subsequent Public Hearing** [Section 76-3-615(4), MCA]

- a. If directed by the governing body pursuant to Section IV-A-9, the Planning Board shall hold a subsequent public hearing for consideration of new information.
  - i. At the subsequent hearing, the Planning Board shall consider only the new relevant information or substantial change to the design of the subdivision that may have an impact on the findings of fact and conditions of approval that will have a substantial effect on the governing body's consideration of the application.
- b. If a subsequent public hearing is held pursuant to Section IV-A-9, it must be held within 45 days of the governing body's determination to schedule a subsequent hearing.
  - i. Notice of the time, date and location of the subsequent hearing shall be posted according to Subsection I-F (b) of these regulations.
- c. If a subsequent public hearing is held, the applicable review period is suspended as of the date of the governing body's decision to schedule a subsequent hearing. The applicable review period resumes on the date of the subsequent public hearing.

**IV-B. Major Final Plats**

The final plat must have the contents and be submitted and reviewed in accordance with the appropriate requirements contained in Section II-B, Final Plats.

## **V. EXPEDITED SUBDIVISION REVIEW**

---

A subdivision application, regardless of the number of lots, that meets the requirements provided in V-A is entitled to the expedited review process at the applicant's request.

### **V-A. Requirements**

A subdivision qualifies for the expedited review process if the proposed subdivision:

- a. is within a county water and/or sewer district created under 7-13-2203 that provides both water and sewer services or an area outside the boundaries of an incorporated city, town, county, or consolidated city-county that is served by city, town, county, or consolidated city-county water and sewer services and is subject to an adopted growth policy as provided in Title 76, chapter 1, and zoning regulations pursuant to Title 76, chapter 2, part 2, that, at a minimum, address development intensity through minimum lot sizes or densities, bulk and dimensional requirements, and use standards;
- b. complies with zoning regulations adopted pursuant to 76-2-203 and complies with the design standards and other subdivision regulations adopted pursuant to 76-3-504; and
- c. includes in its proposal plans for the onsite development of or extension to public infrastructure in accordance with adopted ordinances and regulations.

### **V-B. Exemptions**

A subdivision application that meets the requirements provided in V-A is exempt from:

- a. the preparation of an environmental assessment as required in 76-3-603; and
- b. the review criteria listed in 76-3-608(3)(a).

### **V-C. Subdivision Application Review**

On submission for expedited review, the subdivision application must be reviewed for:

- a. required elements and sufficiency of information as provided in 76-3-601(1) through (3) to determine whether the application complies with zoning regulations adopted pursuant to 76-2-203 and complies with the design standards and other subdivision regulations adopted pursuant to 76-3-504; and
- b. includes in its proposal plans for the onsite development of or extension to public infrastructure in accordance with adopted ordinances and regulations.

The application may include a request for variance from subdivision regulations adopted pursuant to 76-3-504 and in accordance with the provisions of 76-3-506.

#### **V-D. Governing Body Review**

The governing body shall:

- a. hold a hearing and approve, conditionally approve, or deny the subdivision application within 35 working days of a determination by the reviewing agent or agency that the application contains required elements and sufficient information for review as provided in V-C. If the subdivision application includes a request for variance from subdivision regulations adopted pursuant to 76-3-504, MCA the time for holding a hearing must be extended to a total of 45 working days. The governing body may delegate to its reviewing agent or agency the requirement to hold a public hearing on the subdivision application as required in this section.
- b. provide notice for the hearing by publication in a newspaper of general circulation in the county not less than 15 days prior to the date of the hearing;
- c. approve the application unless public comment or other information demonstrates the application does not comply with:
  - i. adopted zoning regulations, design standards, and other requirements of subdivision regulations adopted pursuant to 76-3-504, MCA, including any criteria for granting variances from subdivision regulations adopted pursuant to 76-3-504, MCA; or
  - ii. adopted ordinances or regulations for the onsite development of or extension to public infrastructure; and
- d. provide to the applicant and the public a written statement within 30 days of the decision to approve or deny a proposed subdivision for expedited review as allowed in this section that provides:
  - i. the facts and conclusions that the governing body relied on in making its decision to approve or deny the application; and
  - ii. the conditions that apply to the preliminary plat approval that must be satisfied before the final plat may be approved.
- e. only adopt conditions of approval to ensure an approved subdivision application is completed in accordance with the approved application and any applicable requirements pursuant to Title 76, chapter 4;

#### **V-E. Extensions**

The governing body may, with the agreement of the applicant, grant one extension of the review period not to exceed 180 calendar days.

**V-F. Unlawful Restrictions**

The governing body may not adopt zoning regulations pursuant to 76-2-203 or 76-2-304, MCA, subdivision regulations pursuant to 76-3-504, MCA, or other ordinances or regulations that restrict the use of the expedited subdivision review process as provided in this section.

**V-G. Applicable MSPA Requirements**

Except as modified in this section, subdivision applications meeting the requirements for an expedited review remain subject to the provisions of 76-3-608(3)(b) through (3)(d) and 76-3-608(6) through (10), 76-3-610 through 76-3-614, 76-3-621, and 76-3-625, MCA.

DRAFT

## **VI. DESIGN AND IMPROVEMENT STANDARDS**

---

All subdivisions approved by the governing body must comply with the provisions of this section, except where granted a variance pursuant to Section I-J, Variances. The governing body may not grant variances from the provisions of Section VI-B, Lands Unsuitable for Subdivision, or from the provisions of Section VI-C, Floodplain Provisions. For subdivisions created by rent or lease, condominiums, and RV parks, refer to Sections VII, VIII, and IX of these regulations for additional information.

### **VI-A. Conformance with Regulations**

The design and development of a subdivision must conform with any applicable zoning or other regulations. Where zoning regulations are not in effect establishing maximum densities or minimum lot sizes, maximum density and minimum lot size must be established in consultation with local and state health authorities, including but not limited to the Office of Emergency Management.

### **VI-B. Development Suitability**

#### **a. Natural Environment**

The design and development of subdivisions must provide satisfactory building sites which are properly related to topography, and must, to the extent possible, preserve the natural terrain, natural drainage, existing topsoil, trees, and natural vegetation.

#### **b. Lands Unsuitable for Subdivision**

The governing body may find land to be unsuitable for subdivision because of potential hazards such as flooding, riparian areas, snow avalanches, rock falls, landslides, adverse soil types, mapped/jurisdictional wetlands, steep slopes in excess of 25 percent, high potential for wildfire, subsidence, high water table, polluted or non-potable water supply, high voltage lines, high pressure gas lines, aircraft or vehicular traffic hazards or congestion, or severe toxic or hazardous waste exposure; or because of unreasonable burdens on the general public such as requirements for the excessive expenditure of public funds, environmental degradation, or other features which may be detrimental to the health, safety, or general welfare of existing or future residents. These lands must not be subdivided unless the hazards are eliminated or will be mitigated by approved design and construction plans. [Section 76-3-501(1)(i), MCA]

### **VI-C. Floodplain Provisions** [Section 76-3-504(1)(f), MCA]

Madison County participates in the National Flood Insurance Program (NFIP) and the County has adopted and enforces floodplain development regulations.

Land determined by the governing body to be subject to flooding may not be subdivided for building or residential purposes or other uses that may increase or aggravate flood hazards to life, health, or welfare, or that may be prohibited by state regulations. Land located within the floodway may be used for agriculture, open space, wildlife habitat, parkland, and recreation. Any development within the Regulated Special Flood Hazard Area must be developed in compliance with the Madison County Floodplain Hazard Management Regulations and obtain all necessary permitting.

If identified as necessary during the pre-application meeting by the planner, the subdivider shall complete and submit as part of the preliminary plat application, an engineering study that identifies the Base Flood Elevation (BFE) on the property proposed for subdivision. This detailed evaluation must be performed by a professional engineer licensed in the State of Montana experienced in this field of work.

- a. A copy of the study identifying the BFE shall be submitted with the preliminary plat application to the local planner. The governing body shall forward the study to the Water Resources Division of the Montana Department of Natural Resources and Conservation (DNRC) and county floodplain administrator for comment. The governing body shall not delay the preliminary plat review process to wait for comments from DNRC. Any comments received by the governing body shall be forwarded to the subdivider.
- b. The areas at and below the BFE identified by the engineering study shall be identified on the preliminary plat as flood hazard area and the area shall be identified on the final plat as a no build zone.

#### **VI-D. Design**

##### **a. Improvement Design**

Engineering and survey plans, specifications, and reports required in connection with public and private improvements and other elements of the subdivision application required by the governing body must be prepared by a professional engineer licensed in the State of Montana or a professional land surveyor as their respective licensing laws allow in accordance with the MSPA and these regulations.

If subsequent subdivisions will be served by improvements (roads/streets, fire protection water supplies, storm-water drainage facilities, mailbox facilities etc.) that were installed by a previous subdivider, then the subsequent subdivider may be required to reimburse the previous subdivider for a pro-rata share of the cost of the improvement(s) if all the following criteria are met:

- i. The improvements in question meet the applicable standard; and
- ii. The improvements do not have to be upgraded.

##### **b. Design by Licensed Professionals**

As deemed necessary to protect the public health, safety, and welfare of residents, the governing body may require engineering and survey plans, specifications, and reports required in connection with public improvements associated with a proposed subdivision to be prepared by a licensed professional engineer, in accordance with the Montana Subdivision and Platting Act and these regulations.

#### **VI-E. Lots and Blocks**

##### **a. Lots [Section 76-3-504(1)(g)(i), MCA]**

Each lot must contain a satisfactory building site and conform to county health board regulations, applicable zoning regulations, applicable building regulations and these regulations.

- i. No lot shall be surrounded by another single lot.
- ii. No single lot may be divided by a municipal or county boundary line.
- iii. No single lot may be divided by a public road, alley, and public right-of-way.
- iv. Each lot must have access to a public or private street or road.
- v. Corner lots must have driveway access to the same street or road as interior lots.
- vi. Corner lots must be of sufficient area to provide acceptable visibility for traffic safety.
- vii. No lot may have an average depth greater than three times its average width unless the average width is greater than or equal to 300 feet.
- viii. Side lot lines must be at substantially right angles to street or road lines and radial to curved street or road lines.
- ix. Through lots are prohibited except where essential to provide separation of residential development from traffic arteries or to overcome specific disadvantages of topography or orientation.

**b. Blocks**

Blocks must be designed to assure traffic safety and ease of traffic control and circulation, to accommodate the special needs of the use contemplated, and to take advantage of the limitations and opportunities of the topography.

- i. In incorporated areas, block length must not be more than 1,600 feet if practical, or comply with any applicable zoning standards.
- iii. In unincorporated areas, block length must not be more than 1,600 feet if practical.
  - 1. Blocks must be wide enough to allow for two tiers of lots except where essential to provide separation of residential development from traffic arteries or to overcome specific disadvantages of topography and orientation or unless the governing body approves the design of irregularly shaped blocks indented by cul-de-sacs.
  - 2. Rights-of-way/easements for pedestrian walks, not less than (10) ten feet wide, may be required where deemed essential to provide circulation or safe access to schools, playgrounds, shopping, transportation and other community facilities, or other public health and safety considerations.

**VI-F. Streets and Roads [Section 76-3-504(1)(g)(i), MCA]**

Roads located within a subdivision and any necessary offsite road improvements, shall meet the appropriate County Road Design Standards found in Appendix B of these regulations.

The arrangement, type, extent, width, grade, and location of all streets shall be assessed in respect to existing and planned streets, topographical conditions, public convenience and

safety, and to proposed uses of the land to be served by them.

### c. General Design

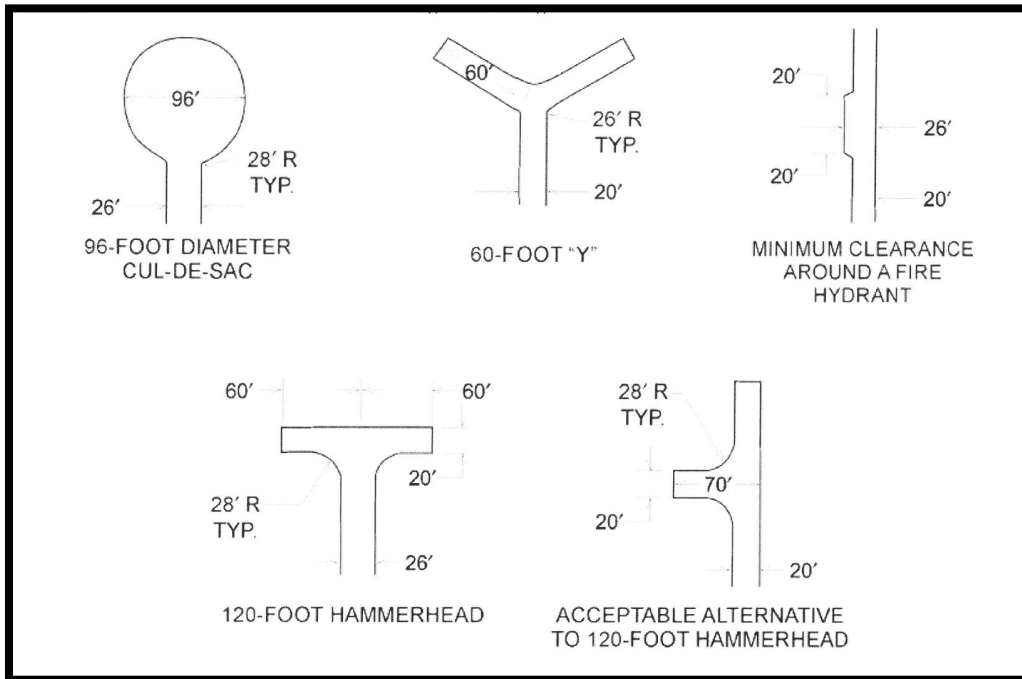

**Figure 1. Road Turnaround Alternatives**

#### i. Roadways

The arrangement, type, extent, width, grade, materials, and location of all roadways shall be considered in their relationship to existing and planned streets and roads, to topographical conditions, maintenance considerations, the delivery of emergency services, to public convenience and safety, in their relation to the proposed uses of the land to be served by them, and to impacted lands outside the subdivision.

#### ii. Relation to Subdivided Areas

The developer shall arrange the roadways to provide for the continuation of roadways between adjacent subdivided parcels when such continuation is necessary for the convenient movement of traffic, effective provision of emergency services, and the efficient provision of utility easements. A condition may be imposed to provide for such continuation of roadways between adjacent subdivided parcels.

#### iii. Relation to Adjoining Lands

Developing subdivisions shall provide access and utility easements to adjoining lands when access to those lands must pass through the subdivision. The developer may be required through a condition of approval to provide legal rights-of-way/easements and the access must be constructed in accordance with these road standards. A county may require the extension of road easements to the edge of a subdivision property to facilitate future subdivision of adjacent lands, if appropriate.

#### iv. Dead-End Roadways

Dead end roads longer than 1,000 feet require an approved turnaround. Refer below to Figure 2 for approved turnaround alternatives. Dead-end roads with an approved turnaround are only permitted on local roads and driveways. All turnarounds must also conform to the design specifications in Table B-1 in Appendix B. Dead end roads longer than 1,500 feet are not permitted.

#### v. Gated Roadways

Gates are not permitted within subdivisions or across subdivision roadways/access.

#### vi. Half Roadways

Half roadways are prohibited except when it is shown that they are beneficial to the County and that they provide for access by emergency service vehicles.

#### vii. Second Access

1. For major subdivisions containing commercial and industrial lots, a second primary access road is required. The second access road shall be designed to the road standards identified in the Madison County Road Standards.
2. For major subdivisions containing residential subdivisions, a second access is required. The second access road shall be designed to the road standards identified in the Madison County Road Standards.

#### viii. Roadway Dedication and Easements

All roads and easements providing access to and within a subdivision will be dedicated for full public use and access.

A road on a final subdivision plat that is dedicated to public use is not a County Road unless the Board of County Commissioners approves by Resolution the adoption of the road as a County road pursuant to Section 7-14-2101, MCA.

#### ix. Roadway Maintenance

1. All internal subdivision roads will be maintained by the property owners of the lots within the subdivision.
2. The final plat for the subdivision shall include a statement on the face of the plat that the property owners owning lots within the subdivision are responsible for the maintenance of roads within the subdivision.

#### x. Drainage Channels and Waterways

1. Bridges and culverts shall be provided and installed by the developer where drainage channels and waterways intersect any road right-of-way or approach. Bridges and large

culverts (48 inches in diameter or more) shall be designed by a professional engineer licensed in the State of Montana.

2. Bridges must be designed and constructed to meet the current edition of the American Association of State Highway and Transportation Officials (AASHTO) Load Resistance and Factor Design (LRFD) Design Specifications. Permits for construction over waterways, including USACE 404 and state permits, may be required.
3. Culverts shall be a minimum of 18 inches in diameter and sized on the estimated stormwater flow generated by the subdivision and shall extend across the entire width of the roadway including the side slope toes. Culvert gauge and depth of backfill shall be included in the design.

xi. Road Naming, Road Signs and Addressing

All proposed road names for roads within the subdivision will be reviewed and approved by the County GIS department. Road name signs shall be installed at all road intersections providing access to and within the subdivision. Road naming, road signs and the addressing of lots in the subdivision will meet the standards found in the Madison County Road Standards and applicable ordinances.

**d. Traffic Study**

i. Vehicle Trip Calculation

1. The Average Daily Traffic Count (ADT) generated by a residential subdivision shall be calculated on the basis of eight trips per household per day, or as identified in a traffic study completed by a professional traffic engineer licensed in the State of Montana.
2. The ADT for commercial/industrial developments must be calculated according to the most current version of Institute of Transportation Engineers (ITE) Trip Generation Manual, or by a traffic study completed by a professional traffic engineer licensed in the State of Montana.

ii. Traffic Studies Required

1. A traffic study completed by a professional engineer licensed in the State of Montana is required for the following subdivisions:
  - a) For all commercial and industrial subdivisions.
  - b) For all subdivisions whose primary access is on a major or minor collector in the jurisdiction that will generate more than 250 ADT.
  - c) For all subdivisions whose primary access is on a local road in the jurisdiction that will generate more than 250 ADT.
  - d) When a traffic study is required by the Montana Department of Transportation (MDT) for any access or approach onto an MDT roadway.

### iii. Traffic Studies Content

1. A traffic impact study developed by a professional traffic engineer, licensed in the State of Montana, and shall be based upon the current editions of Institute of Transportation Engineers (ITE) standards and the Highway Capacity Manual and includes the following:
  - a) existing traffic volumes;
  - b) existing traffic conditions: lanes, traffic control, access control, etc.;
  - c) projected traffic volumes (based upon subsection d(ii) Traffic Studies Required or ITE standards, as applicable) of internal, adjacent, and off-site roads affected by vehicle traffic to be generated by the subdivision;
  - d) projected traffic distribution and assignment on adjacent, and off-site roads affected by vehicle traffic to be generated by the subdivision;
  - e) Traffic analysis, including existing and projected Levels of Service (LOS) etc. of internal, adjacent, and off-site roads and intersections affected by vehicle traffic to be generated by the subdivision;
  - f) conclusions and recommendations including any needed upgrades to existing roads, bridges, culverts and intersections. Conditions may be imposed on the subdivision to improve roads, bridges, culverts and intersections in accordance with the conclusions and recommendations or other factors; and
  - g) Traffic studies submitted with subdivision applications must include data obtained and calculated within two years of the application submittal and include data collected during peak visitor season for the project location, reflecting both weekday and weekend traffic counts at peak traffic hours.

### e. Improvements

- i. All roadway improvements including pedestrian trails, utilities, and drainage facilities must be constructed in accordance with the standards prescribed in these regulations.
- ii. Roadway subgrades must be free of topsoil, sod, vegetation or organic matter, soft clay, or other substandard materials.
- iii. Streets and roads must be designed to ensure proper drainage, including but not limited to surface crown, culverts, curbs and gutters, drainage swales and storm drains.
- iv. In unincorporated areas where access from a public road to the subdivision will cross properties not owned by the subdivider, the subdivider must obtain road easements in compliance with these design and improvement standards, from each property owner or the appropriate administrator of public lands. Each easement must allow construction and perpetual maintenance of a road accessing the property and allow vehicular travel on the road. The easement shall either be dedicated to the public, or the subdivision at the discretion of the governing body.

1. Easements granting full public access for vehicle use must be created by each property owner through a signed and notarized document filed with the County Clerk and Recorder. The easement shall grant access in conformance with road standards found within these regulations and fully identifies the location of the easement via a metes and bounds description or via a surveyed exhibit filed with the easement document.
  2. The location of any road easement must be shown on the plat or on a supplemental map. The existence of easements must be noted on the face of the final plat and on any deeds or other instruments conveying lots within the subdivision.
- v. Existing trees and other vegetation must be preserved whenever possible. Plantings may be required for buffering, screening, or soil erosion protection and are subject to approval by the governing body. Barrow areas for roads must be seeded with approved plant materials to reduce erosion.
  - vi. Street light installation may be required by the governing body where necessary for public, health and safety purposes on all roads within the subdivision.
  - vii. Approach/Encroachments onto MDT roads and highways must be permitted and built according to MDT requirements prior to final plat.

**f. Off-Site Roadway Improvements**

- i. The governing body shall require off-site road improvements outside the subdivision when the improvements are proportional to the direct impact of the subdivision. Necessary off-site road improvements and proportional costs of improvements shall be based on the recommendations of the traffic study required according to Subsection VI-F (d) and as agreed by the applicable agency.
- ii. The subdivider shall either complete the necessary proportional improvements or pay the County the proportional costs of the improvements prior to filing the final plat. The funds paid by the subdivider shall be held by the County to fund future improvements to the road(s) in question.

**g. Walkways and Bikeways**

- i. Pedestrian walks may be required in order to provide circulation or safe access to schools, playgrounds, shopping, transportation, and other community facilities.
- ii. Bikeways may be considered in the planning of a subdivision. Bikeways should be built to the minimum standards given in the American Association of State Highway & Transportation Officials (AASHTO) "Guide for the Provision of Bicycle Facilities".

**h. Definitions and Classification Standards**

- i. Arterial Roads

Arterial roads are designed to move vehicles through an area. The roads have limited access, higher speeds and may have traffic signals near populated areas. Arterials should ideally have a wider shoulder than other roads. Wider shoulders allow more room for people to pull over if

they have vehicle trouble, plus they provide additional room for wide loads or recovery associated with loss of vehicle control. A six-foot shoulder is consistent with Montana Department of Transportation (MDT) standards for rural roads with more than 550 vehicles per day. The MDT standard for a bike lane varies from four to five feet and the six-foot shoulder allows for cyclists to use the shoulder. Secondary arterials typically have lower volumes and narrower shoulders than primary arterials. The only roads designated as arterial roads within Madison County are the Primary State Highways.

ii. Major Collectors

Major collectors are designed to serve both traffic movement and access. The roads are typically paved and have cross-road access but limited private driveway access and medium to high speeds. State Secondary Highways in the County are designated as major collectors.

iii. Minor Collectors

Minor collectors are similar to major collectors except they may carry a greater level of localized traffic, and their condition may not be as high a priority as major collectors. The roads typically have limitations to road or driveway access and medium speeds similar to those on major collectors. Designation of a road as a minor collector shall be completed through the completion of a traffic impact study as described in Section VI-H(b).

iv. Local Roads

Local roads are streets with the lowest traffic volumes. They are designed to offer access to farms, ranches, and residences, connecting driveways to collectors or arterials. Most of the roads in the County are classified as local roads. There are two types of local roads based upon ADT's:

1. Local roads – gravel surfaced, 1 to 400 ADT's
2. Local roads-asphalt surfaced, 401 to 1,000 ADT's

**VI-G. Postal Service**

Mail delivery to a subdivision must comply with the requirements of the United States Postal Service and Madison County addressing and road naming ordinances.

**VI-H. Stormwater Drainage Facilities**

The drainage system and facilities required for any surface run-off affecting the subdivision are subject to approval by the governing body. Subdivisions containing lots less than 20 acres in size must also be reviewed and approved under Title 76, Chapter 4, MCA, by the DEQ.

- a. A grading and drainage plan, as required by Section II-A-2, shall be developed by a professional engineer licensed in the State of Montana.
- b. Where proposed subdivision lots are less than twenty (20) acres in size, the drainage system and facilities required for any surface runoff affecting the proposed subdivision or adjacent properties

shall meet the minimum drainage standards of the Montana Department of Environmental Quality. Where proposed subdivision lots are twenty (20) acres or larger in size, such drainage system and facilities shall have the approval of the County Sanitarian.

- c. Curbs and gutters or swales will be required based on the character of the area, density of development, and nature of adjoining properties. Curbs and gutters of adjoining properties must be extended in conformance with current specifications of local and state authorities.
- d. Culverts and bridges of adequate size must be provided and installed by the subdivider where drainage channels intersect any street or road right-of-way or easement. All culverts and bridges must be constructed and installed according to applicable local and state standards. Culverts and other drainage facilities must be large enough to accommodate potential run-off from upstream drainage areas.
- e. Each culvert or other drainage facility must be large enough to accommodate potential run-off from upstream drainage areas for the 10-year, 24-hour storm event.
- f. The subdivider must provide suitable drainage facilities for any surface run-off affecting the subdivision. These facilities must be in street rights-of-way or in perpetual easements of appropriate widths.
- g. Drainage systems must not discharge into any sanitary sewer facility.
- h. The governing body may require the subdivider to grant easements to prevent encroachment or disruption of drainageways or facilities. Drainage easements must be shown on the plat and a signed statement granting the easements must appear on the plat.

#### **VI-I. Water Supply Systems**

##### **a. General**

- i. All water systems are subject to approval by the governing body.
- ii. Water systems required by the governing body shall meet the minimum requirements of the local reviewing authority, the Montana Department of Environmental Quality and the Montana Department of Natural Resources and Conservation. Subdivisions containing lots less than 20 acres in size must be reviewed and approved under Title 76, Chapter 4, MCA, by the DEQ prior to approval of the final plat.
- iii. For subdivisions creating one or more parcels containing 20 acres or more, the subdivider shall submit the required information for the parcel containing 20 acres or more only to the local reviewing authority and the planner. DEQ review and approval is not required. This demonstration to the local reviewing authority is to evaluate the ability to develop lots and is not a guarantee that a source of water will be available when the lots are developed.

##### **b. Type of System**

- i. Any system with more than two connections must be designed by a professional engineer licensed in the State of Montana and reviewed by DEQ.

- ii. The governing body may require that any proposed central system provide adequate and accessible water for fire protection.
- iii. Where the subdivision is within the service area of a municipal system, or a public water supply system, the subdivider must install complete water system facilities in accordance with the requirements of the jurisdiction involved and the DEQ. The subdivider must submit plans and specifications for the proposed facilities to the jurisdiction involved and to the DEQ and must obtain their approvals prior to undertaking any construction.

#### **VI-J. Wastewater Treatment Systems**

- a. All wastewater treatment systems are subject to the approval of the governing body.
- b. Systems for subdivision lots less than 20 acres in size must meet the minimum standards of the local reviewing authority, and DEQ which are incorporated into and made a part of these regulations by this reference, prior to final plat approval.
- c. For a proposed subdivision that will create one or more parcels containing 20 acres or more, the subdivider shall demonstrate to the local reviewing authority adequate evidence that a sewage disposal facility is sufficient in terms of capacity for the parcels containing 20 acres or more. In addition, the subdivider shall demonstrate that there is at least one area for a septic system and a replacement drain field for each lot. This demonstration to the local reviewing authority is to evaluate the ability to develop lots at the platting stage and is not a guarantee that a location for a septic system or drain fields will be available when the lots are developed.
- d. Where the subdivision is within the service area of a municipal or public sanitary sewer system, the subdivider must install complete sanitary sewer system facilities in accordance with the requirements of the jurisdiction involved and the DEQ. The subdivider must submit plans and specifications for the proposed facilities to the jurisdiction involved and to the DEQ and must obtain their approvals prior to undertaking any construction.

#### **VI-K. Utilities** [Section 76-3-504(1)(g)(iv), MCA]

- a. The subdivider must provide adequate and appropriate easements for the construction of utilities within the subdivision. The subdivider must obtain any easements necessary to extend utilities to the subdivision.
- b. All public and private utilities should be placed underground when technically feasible. Underground utilities, if placed in the road right of way, shall be located between the roadway and the right of way line to simplify location and repair of lines. Overhead utilities, shall be located at the rear of the property line, where practical.
- c. Utility facilities must be designed by utility firms in cooperation with the subdivider, subject, however, to all applicable laws and all rules and regulations of any appropriate regulatory authority having jurisdiction over such facilities. Utility easements must be located along the side, and rear lot lines wherever necessary.
- d. Utility easements must be a minimum of 15 feet wide unless otherwise specified by a utility company or the governing body.

- e. All gas systems serving the subdivision shall be designed and constructed in accordance with the most recent edition of the National Fuel Gas Code and the Standard for the Storage and Handling of Liquefied Petroleum Gases.
- f. In addition to showing the location of the utility easement on the plat with dashed lines, the following statement must be on the final plat:

*"The undersigned hereby grants unto each and every person, firm, or corporation, whether public or private, providing or offering to provide telecommunications, electric power, gas, cable television, water, or sewer service to the public, the right to the joint use of an easement for the construction, maintenance, repair and removal of their lines and other facilities, in, over, under and across each area designated on this plat as 'Utility Easement' to have and to hold forever."*

#### **VI-L. Construction Setbacks from Water Bodies**

##### **a. Construction Setbacks from Water Bodies**

(not including irrigation ditches, which are addressed in Section VI-M).

##### **i. Purpose**

The purpose of these construction setbacks is to:

1. Protect the water quality, floodplain, wildlife habitat, and riparian areas of the rivers and other water bodies in Madison County
2. Protect the visual resource enjoyed from these water bodies; and
3. Provide for the health and safety of the residents of Madison County.

##### **ii. Applicability**

The construction setbacks are applicable to all structures, subdivision improvements, utility installations, and construction activities. Exceptions to the construction setback standards allow for necessary permitted water body crossings (i.e. 124, 310, 318, 404 permits) that are designed to address water quality. Any modification to the applicable setbacks requires approval of a variance request.

##### **iii. Setbacks**

1. The minimum construction setback from the Madison River shall be 500 feet from the ordinary high-water mark.
2. The minimum construction setback from the Big Hole River, the Jefferson River, the Ruby River, the Beaverhead River, and the South Boulder River shall be 150 feet from the ordinary high-water mark, unless the floodplain development permit stipulates a greater construction setback or unless analysis of the subdivider's affected identifies a need for a greater construction setback. In such cases, the greater construction setback shall prevail.
3. The minimum construction setback from other water bodies shall be 100 feet from the bank.

**VI-M. Water Course and Irrigation Easements** [Section 76-3-504(1)(k) and (l), MCA]

- a. The subdivider shall establish within the subdivision ditch easements that:
  - i. Are in locations of appropriate characteristics and sufficient width to allow the physical placement and unobstructed maintenance of open ditches or below ground pipelines for the delivery of water for irrigation to persons and land legally entitled to the water under an appropriated water right or permit of an irrigation district or other private or public entity formed to provide for the use of the water right on the subdivision lots;
  - ii. Are 30' from the centerline of the ditch, on one or both sides of the ditch depending on topography and location, to allow for construction, repair, maintenance, and inspection of the ditch; and
  - iii. Prohibit the placement of structures, as defined in these regulations, or the planting of vegetation other than grass within the ditch easement without the written permission of the ditch owner.
- b. The subdivider shall, unless otherwise provided under separate written agreement or filed easement, show on the preliminary final plat, and file and record with the County Clerk and Recorder, ditch easements for the unobstructed use and maintenance of existing water delivery ditches, pipelines, and facilities in the proposed subdivision that are necessary to convey water through the subdivision to lands adjacent to or beyond the subdivision boundaries in quantities and in a manner that are consistent with historic and legal rights. A minimum width of 10 feet is required on each side of irrigation canals and ditches for maintenance purposes.

**VI-N. Disposition of Water Rights** [Section 76-3-504(1)(j), MCA]

If a subdivision will create lots averaging less than five acres in size, the subdivider shall submit evidence with the final plat that the subdivider has: [Section 76-3-504(1)(j), MCA]

- a. reserved all or a portion of the appropriation water rights owned by the owner of the land to be subdivided and transfer these water rights to a single entity for use by landowners within the subdivision who have a legal right to the water and reserved and severed any remaining surface water rights from the land;
- b. if the land to be subdivided is subject to a contract or interest in a public or private entity formed to provide for the use of a water right on the subdivision lots, established a landowner's water use agreement administered through a single entity. This agreement must specify how the water rights will be administered and describe the rights and responsibilities of landowners within the subdivision who have a legal right and access to the water; or
- c. reserved and severed all surface water rights from the land proposed for subdivision.

**VI-O. Park Land Dedication – Cash in Lieu – Waivers – Administration** [Sections 76-3-504(1)(h) and 76-3-621, MCA]

- a. Except as provided below, the final plat of a residential subdivision must show that the subdivider has dedicated to the governing body a cash or land donation equal to:
  - i. 11% of the area of the land proposed to be subdivided into parcels of one-half acre or smaller;
  - ii. 7.5% of the area of the land proposed to be subdivided into parcels larger than one-half acre and not larger than one acre;
  - iii. 5% of the area of the land proposed to be subdivided into parcels larger than one acre and not larger than three acres; and
  - iv. 2.5% of the area of the land proposed to be subdivided into parcels larger than three acres and not larger than five acres.
- b. A park dedication is not required for:
  - i. Minor subdivisions in unincorporated areas;
  - ii. subdivision lots larger than five acres;
  - iii. nonresidential subdivision lots;
  - iv. subdivisions in which parcels of land will not be created, other than subdivisions that will provide permanent multiple spaces for recreational camping vehicles, mobile homes, or condominiums; or
  - v. subdivisions which will create only one additional parcel.
- c. The governing body, in consultation with the subdivider and the Planning Board or park board that has jurisdiction, may determine suitable locations for parks and playgrounds and, giving due weight and consideration to the expressed preference of the subdivider, may determine whether the park dedication must be a land donation, cash donation, or a combination of both. When a combination of land donation and cash donation is required, the cash donation may not exceed the proportional amount not covered by the land donation. The land dedicated for park use may be inside or outside the boundaries of the proposed subdivision.
- d. The governing body **will** waive the park dedication requirement if it determines that:
  - i. the preliminary plat provides for development with land permanently set aside for park and recreational uses sufficient to meet the needs of the persons who will ultimately reside in the development; and
  - ii. the area of the land and any improvements set aside for park and recreational purposes equals or exceeds the area of the dedication required under Section VI-O (a); and
  - iii. the proposed subdivision will provide for the long-term protection of critical wildlife habitat; cultural, historical, or natural resources; agricultural interests; or aesthetic values; and

- iv. the provision of this long-term protection will result in the reduction of the area of the land proposed to be subdivided by an amount equal to or exceeding the area that would have had to be dedicated under Subsection VI-O (a) above;
  - v. the area of the land proposed to be subdivided, by virtue of a combination of the provisions of Subsections (d)(i) and (ii) above, is reduced by an amount equal to or exceeding the area of the dedication required under Section VI-O (a); or
  - vi. the subdivider provides for land outside of the subdivision to be set aside for park and recreational uses sufficient to meet the needs of the persons who will ultimately reside in the subdivision; and
  - vii. the area of the land and any improvements set aside for park and recreational uses equals or exceeds the area of dedication required under Subsection VI-O (a).
- e. The governing body **may** waive the park dedication requirement if:
- i. the subdivider provides land outside the subdivision that affords long-term protections of critical wildlife habitat, cultural, historical, or natural resources, agricultural interests, or aesthetic values; and
  - ii. The area of land to be subject to long-term protection, as provided in Subsection (e)(i), equals or exceeds the area of dedication required under Section VI-O (a).
- f. Subject to the approval of the local governing body and acceptance by the school district trustees, a subdivider may dedicate a land donation provided under Section VI-O (a) to a school district, adequate to be used for school facilities or buildings.
- g. The governing body will administer funds dedicated to the public under this section in accordance with Section 76-3-621, MCA.
- h. For the purposes of this park dedication requirement:
- i. “cash donation” means the fair market value of the unsubdivided, unimproved land; and
  - ii. “dwelling unit” means a residential structure in which a person or persons reside.

**VI-P. Fire Protection** [Section 76-3-501(1)(i), MCA]

All subdivisions must be planned, designed, constructed, and maintained to minimize the risk of fire and to permit the effective and efficient suppression of fires to protect persons, property, and forested areas. The creation of lots and the placement of structures in a subdivision should be in such a manner to minimize the potential for flame spread and to permit efficient access for firefighting equipment.

The presence of adequate firefighting facilities, including an adequate water supply, is vital to the safety of a subdivision. The governing body shall require the installation of storage tanks with pumping systems, ground water wells with a pumping system, a dry hydrant system or other means

of fire suppression with water as approved by the governing body. An approved system must provide a water supply volume adequate to suppress the fire as determined by these regulations.

Access for emergency services and escape routes for residents are a critical component for providing adequate fire protection for most new subdivisions. Therefore, for major subdivisions (6 or more lots), two (2) separate ingress/egress routes (public roads) shall be provided for the subdivision. Higher standards may be required, if recommended by the local fire district or fire prevention specialist.

Mitigation will be required if the estimated emergency response time to a proposed subdivision site exceeds 15 minutes. All subdivisions located within or adjacent to the Wildland Urban Interface shall follow the design and development standards of the Wildland Urban Interface Code, prepared by the International Code Council. All subdivisions should refer to the Madison County Community Wildfire Protection Plan for guidance on design and fire defensibility.

#### **VI-Q. Fire Protection Water Supplies**

All subdivisions must have some level of fire protection. Adequate and accessible water for fire protection within one mile is a requirement of subdivision.

A water supply of sufficient volume for effective fire control must be provided within the subdivision as follows:

- a. All fire protection water supply systems must be designed by a professional engineer licensed in the State of Montana. The County's preference would be that an engineer with experience designing fire protection water supplies work on the project. The system must be designed in consultation with the local fire authority having jurisdiction to ensure compatibility with the authority's fire-fighting equipment.
- b. Prior to filing the final plat, all systems shall be installed and inspected and certified as meeting the necessary standards and are fully operational by a Professional Engineer licensed in the State of Montana. A copy of the inspection and certification will be provided to the local fire authority having jurisdiction.
- c. Maintenance of the fire protection water supply and vehicle access:
  - i. A notation on the final plat shall state that the property owners within the subdivision are responsible for the maintenance of the system. The local fire authority having jurisdiction shall not be responsible for any maintenance or costs associated with the operation, upgrades, or other measures necessary to ensure the system functions as designed.
  - ii. A vehicular public access easement ensuring unrestricted use by the local fire authority having jurisdiction, shall be established in perpetuity, and shall be identified and recorded on the final plat.
  - iii. The system shall be located adjacent to the following type of road in order of preference:
    1. A County-maintained road;
    2. A State-maintained highway;

3. A subdivision road that is designated as a public access easement.

d. Water shall be supplied by one of the following methods:

- i. A pressurized storage tank capable of providing a minimum flow of 1000 gallons per minute at a minimum of 20 PSI for 30 minutes. The storage tank must be made of non-corrosive materials that have not been previously used for storage of any substance and are usable year-round.
- ii. A well and pump, in a pump house, providing a minimum flow of 1000 gallons per minute at 20 PSI for 30 minutes. This includes a year-round supply of electricity to run the pump. In addition, for winter months, the pump house shall be heated as appropriate in order for the well to operate.
- iii. A dry hydrant providing a minimum flow of 1000 gallons from water sources such as a pond or stream. The source shall have a minimum annual water level or flow sufficient to meet the water supply needs as required by these regulations. The supply shall not be rendered unusable because of freezing or seasonal low water. Adequate water rights to access the water shall be ensured in a manner acceptable to the local fire authority having jurisdiction and the governing body.
- iv. An alternative fire protection water supply designed by a licensed professional engineer in the State of Montana with a minimum flow of 1000 gallons per minute at a minimum of 20 PSI for 30 minutes and as reviewed and approved by the governing body.
- v. Existing off-site water supply systems may be used to meet these standards if they meet the following conditions:
  1. The system meets the necessary flow rates and storage identified in these regulations.
  2. The subdivider has secured any necessary easements and/or agreements from the affected property owner(s) and/or homeowners association.
  3. The system has an effective maintenance system in place and is shown to be fully operational by a professional engineer licensed in the State of Montana. The governing body shall determine if the system maintenance is effective.
  4. Use of the existing off-site water supply system will not diminish the fire protection capabilities provided to the subdivision(s) it was originally built to serve or it is upgraded and/or expanded to provide volume, pressure, and distribution in accordance with these regulations for all subdivisions utilizing the system for fire protection in accordance with these regulations.

e. Fire Protection Water Supply Storage Capacity by Subdivision Classification:

- i. Minor subdivisions (5 or less lots): A minimum of a 30,000-gallon storage capacity or the equivalent amount of water by other allowed methods listed in subsection d above must be installed at the time of filing the final plat.

- ii. Major subdivisions (6 or more lots): A minimum of a 30,000 gallon or the equivalent amount of water by other allowed methods listed in subsection d above and additional storage per proposed lot over six (6) lots as determined by the local fire protection authority having jurisdiction; at the time of the filing of the final plat.

## **VI-R. Special Requirements for Subdivisions Proposed in Areas of High Fire Hazard**

### **a. Risk Determination**

Prior to submitting an application for preliminary plat approval, the subdivider shall contact the local fire authority having jurisdiction to ask the authority to make a determination whether the subdivision is located in a high fire risk area. The local fire authority shall have 10 working days to make this determination. This determination shall be based on one or more of the following criteria:

- i. The proposed subdivision is located in an area identified as Wildland Urban Interface.
- ii. The proposed subdivision is located in an area with a high density of fuels and/or slopes greater than 25%.
- iii. The proposed subdivision contains a density of more than one (1) lot per three (3) acres.
- iv. The proposed subdivision is located more than ten (10) miles from a fire station.
- v. The proposed subdivision includes heads of draws, excessive slopes, dense forest growth or other hazardous wildfire components.
- vi. The proposed subdivision in areas subject to high wildfire hazard as determined by the local fire authority, U.S. Forest Service or the Forestry Division of the Montana Department of Natural Resources and Conservation.

### **b. High Fire Risk Determination**

If the determination is made that the property proposed for subdivision is located in an area of high fire risk, the following standards apply:

- i. A Fire Prevention and Control Plan, acceptable to the local fire authority, must accompany the submission of any application for preliminary plat approval.
- ii. The Fire Prevention and Control Plan must include the following items:
  - 1. an analysis of the wildfire hazards on the site, as influenced by existing vegetation and topography.
  - 2. a map showing the areas that are to be cleared of dead, dying, or severely diseased vegetation.
  - 3. a map of the areas that are to be thinned to reduce the interlocking canopy of trees.

4. the identification of roads, driveways, and bridges that are sufficient for emergency vehicle access and fire suppression activities. Slopes of all roads must be provided.
- iii. At least two separate ingress/egress access roads or routes must provide escape routes for residents and access to the subdivision by fire-fighting vehicles. Bridges providing access to the subdivision must be built to a design load of HL-93 (80,000 pounds) and constructed of nonflammable materials. Road rights-of-way must be cleared of wildland fuel a minimum of 50' either side of roads measured from road center.
- iv. Building sites may not be located on slopes greater than 25% or at the apex of "fire chimneys" (topographic features, usually drainageways or swales, which tend to funnel or otherwise concentrate fire toward the top of steep slopes). Building envelopes shall be shown on the face of the final plat for each lot to ensure no construction occurs on slopes over 25%.
- v. The Fire Prevention and Control Plan must be implemented before the governing body will approve the final plat and will be considered part of the subdivider's obligations for land development. The local fire authority having jurisdiction, will inspect and approve the implementation of the Fire Prevention and Control Plan. The Plan will not be considered fully implemented until the fire chief has given written notice to the planning board or planner that the Plan has been completed as approved by the governing body.
- vi. Provisions for the maintenance of the Fire Prevention and Control Plan shall be included in the conditions, and restrictions for the development.
- vii. Open space, parkland, and recreation areas (including green belts, riding, or hiking trails) should be located, where appropriate, to separate residences and other buildings from densely forested areas.

#### **VI-S. Noxious Weeds**

A Noxious Weed Management and Revegetation Plan shall be developed and implemented for every new subdivision. The applicant must meet the requirements of the plan prior to filing the final plat. The final Weed Management and Revegetation Plan must be prepared by the County Weed Coordinator, approved by the Madison County Weed Board, signed and notarized by the subdivider, and recorded with the final plat.

#### **VI-T. Landscape Buffer**

The governing body may require a landscape buffer to mitigate impacts to public health and safety. If required to mitigate impacts, the applicant shall submit a conceptual landscape plan for a 25-foot buffer. The landscape plan shall contain a combination of berms and/or planting that will provide an effective buffer. The landscaping shall be installed prior to final plat approval. The buffer must be shown as a 25-foot setback on the face of the final plat. A maintenance agreement shall be filed for the maintenance of the landscaping.

#### **VI-U. Building Envelopes**

Building envelopes are an optional component of subdivision design but may be required on small lots (less than five acres) and/or on lands with environmentally sensitive features, as determined by

the planner or the governing body. Building envelopes shall be shown either on the final plat (platted) or on a building envelope plan exhibit (recorded) and be referenced on the plat. A copy of any building envelope plan shall also be provided to the Planning Department, to be kept on file.

Where building envelopes are included on the recorded plat, any modification or amendment to these platted building envelopes will require an Amended Plat application (see Section II-B-6 and Appendix 21). Where building envelopes are filed and recorded as a plan exhibit instead, any modification or amendment will be reviewed administratively by the planner to ensure compliance with the subdivision approval or geotechnical restrictions. Appeal of the planner's decision regarding a building envelope modification may be made to the governing body.

#### **VI-V. Right-to-Farm**

Section 27-30-101, MCA, affirms the following: "An agricultural or farming operation, place, establishment, or facility or any of its appurtenances or the operation of those things is not or does not become a public or private nuisance because of the normal operation as a result of changed residential or commercial conditions in or around its locality if the agricultural or farming operation, place, establishment, or facility has been in operation longer than the complaining resident has been in possession or commercial establishment has been in operation."

In the interests of supporting the viability of agriculture in Madison County and pursuant to 27-30-101, MCA, each subdivision application shall include a Right-to-Farm declaration, to include the notarized signatures of the landowner(s) (Appendix 10). Such declaration shall be filed along with the summary or final plat. Any covenants designed to provide further protections to agricultural operations in the general vicinity of the proposed subdivision shall be plat approval covenants, also filed with the summary or final plat.

#### **VI-W. Geological Review/Geotechnical Report**

For sound regional and local land use planning and development, the complex geological framework of Madison County requires that County officials, developers, and the general public must have appropriate geoscience information. The most critical information, in general, is that which identifies areas of real or potential hazards, related to the geology, that could endanger the public or become matters of environmental or public health concern.

To provide this information, the local governing body requires a geological review/geotechnical report of any property planned for subdivision, to identify areas, if any, that are not suitable for development. This report shall be performed by a Licensed Professional Geologist, a Professional Geologist certified by the American Institute of Professional Geologists, or by a Professional Engineer licensed by the State of Montana, with a demonstrated proficiency in geological engineering and engineering geology. A written report signed with an appropriate professional seal, shall be furnished to Madison County with preliminary plat application. The report shall describe geological conditions, with maps that clearly show areas of geology-related hazards, and shall discuss the risks associated with geology-related hazards in terms easily understood by non-geologists. If the report identifies geology-related concerns, the local governing body may require that site-specific geological and geotechnical investigations are needed before actual construction. Where a geological review/geotechnical report is not

submitted with the preliminary plat application, the Planning Board may recommend and the governing body may require it as a condition of preliminary plat approval; this determination will be guided by information collected during the preliminary plat review process. Subdivision applications that exclusively include existing structures/development are exempt from providing a geological review/geotechnical report.

#### **VI-X. Lighting**

All outdoor lighting and lighting fixtures within subdivision shall be designed and constructed in a manner to ensure that:

- a. No lighting treatment shall, whether by brilliance or reflected light, be a detriment to surrounding properties or prevent the reasonable enjoyment of adjacent properties.
- b. Exterior lighting shall be arranged and directed downward to minimize illumination beyond property lines.
- c. Street lighting must be configured with a horizontal cutoff and positioned so as to minimize any objectional direct glare source and not create light trespass.
- d. Where signs are illuminated, the illumination shall shine only on the sign or on the property on which the sign is located. Sign illumination shall not shine onto any other property in any direction, except by indirect reflection.
- e. All outdoor lighting must be directed so as to avoid glare and excessive light spillage on adjacent properties.

#### **VI-Y. Signage**

Any signage associated with the subdivision shall not project or extend into a public right-of-way or impede right-of-way sight visibility and must comply with all County ordinances.

#### **VI-Z. Other Resource Protection**

In designing the development proposal, the subdivider shall consider the historic, cultural, and scenic resources of Madison County and attempt to minimize any negative impact of the proposed subdivision on such resources. In particular, the subdivider may be required to notify the Montana State Historical Society prior to submitting the subdivision application, in order to determine the potential for existing significant historic resources. If the Historical Society recommends a “walk-through” or inventory of historic resources on the land proposed for subdivision, such action shall be taken prior to submittal of the subdivision application and prior to any construction activity connected with the proposed subdivision.

If County review determines that a proposed subdivision may negatively impact the historic, cultural, and scenic resources of Madison County, a building setback, building envelope, or other special design/development standard may be required in order to mitigate project impacts.

## VII. SUBDIVISIONS PROVIDING MULTIPLE SPACES FOR RECREATIONAL CAMPING VEHICLES OR MOBILE/MANUFACTURED HOMES

---

### VII-A. General

#### VII-A-1. Definitions

A subdivision that provides or will provide multiple spaces for rent or lease on which recreational camping vehicles or mobile/manufactured homes will be placed shall be reviewed according to this chapter. If the land creating the recreational camping vehicle or mobile home spaces is being divided from a parent tract and the tract for the spaces is less than 160 acres or the remaining portion of the parent tract is less than 160 acres, subdivision review will be required pursuant to these regulations set forth in Section III or IV.

Spaces and pads which are designated through this process as being for rent or lease do not result in a division of land whose title can be conveyed.

##### a. **Mobile/Manufactured Homes Parks**

Developments which are subject to subdivision review because they will provide two or more spaces for mobile/manufactured homes will be reviewed under Section VII-B-2. Mobile/Manufactured Home Park Standards, below.

##### b. **Recreational Camping Vehicles Parks**

Developments which are subject to subdivision review because they will provide two or more spaces for recreational camping vehicles will be reviewed under Section VII-B-3. Recreational Vehicle Park Standards, below.

##### c. **Conversion to Condominium Use**

Any subdivision which will provide multiple spaces for recreational camping vehicles or manufactured or mobile homes which is converted to condominium use must be reviewed pursuant to Section VIII (Condominiums).

##### d. **Preliminary Site Plan**

A preliminary site plan shall be submitted at the time of preliminary plat application which shall be a conceptual plan of the spaces for rent or lease showing at minimum the boundaries of the subject parcel, the location of spaces, pads, roads, storage areas, parking areas, location of common areas and facilities, location of parks and/or recreation areas if required, and any other information deemed necessary by the governing body.

## **e. Final site plan**

A final site plan of the subdivision providing multiple spaces for rent or lease shall be submitted at the time of final plat application showing at minimum the location of spaces, pads, roads, storage areas, parking areas, location of common areas and facilities, location of parks and/or recreation areas if required, and any other information deemed necessary by the governing body or necessary to meet conditions of preliminary approval. The site plan shall be submitted to the Clerk and Recorder with the final plat at the time the final plat is recorded.

## **VII-A-2. Review and Approval [Section 76-3-504(1)(s), MCA]**

### **a. Submittal Requirements**

- i. The subdivider shall submit a completed application in accordance with Section II-A-2 Subdivision Application and Preliminary Plat Submittal, and a plan of the proposed development conforming to the requirements for preliminary plats.
- ii. In addition, the requirements outlined Section II-A-2, preliminary applications for mobile home parks, manufactured home parks and RV parks shall submit a preliminary site plan showing the following:
  1. A layout of all spaces, pads, buildings, structures, common areas and other facilities proposed for rent or lease, including facilities such as shower houses and toilet facilities, indoor eating areas, convenience stores and indoor recreational facilities; and
  2. Location and dimension of internal roads and parking areas.

### **b. Preliminary Plat Approval**

- i. Proposed subdivisions providing multiple spaces for rent or lease are subject to the initial review process for preliminary plats found in Section II-A-2 Review Process.
- ii. Proposed subdivisions providing multiple spaces for rent or lease creating five or fewer spaces must be reviewed according to Section III Minor Subdivisions.
- iii. Proposed subdivisions providing multiple spaces for rent or lease creating more than five spaces must be reviewed according to Section IV Review and Approval Procedures for Major Subdivisions.
- iv. Proposed subdivisions providing multiple spaces for rent or lease that will expand an existing subdivision for rent or lease resulting in the accumulative total of more than five spaces must be reviewed according to Section IV Review and Approval Procedures for Major Subdivisions.

### **c. Final Plat Approval**

- i. The applicant shall submit an application for final plat in accordance with the procedures outlined in Section II-B Final Plats.

1. The final plat application shall include a final site showing the perimeter of the proposed park and any additional spaces that were created.
2. The final site plan, showing the following shall be included with the final plat application and filed at the Clerk and Recorder:
  - a) A layout of all spaces, pads, buildings, structures, common areas and other facilities proposed for rent or lease, including facilities such as shower houses and toilet facilities, indoor eating areas, convenience stores and indoor recreational facilities; and
  - b) location and dimension of internal roads and parking areas.
- ii. The subdivider shall install all required improvements prior to approval of the final plat and plan. The governing body or its agents will inspect all required improvements to assure conformance with the approved conditions, construction plans and specifications.
- iii. If a subdivision that will provide multiple spaces for recreational camping vehicles or mobile homes is also a “trailer court,” “work camp,” “youth camp,” or “campground” as those terms are defined in Section 50-52-101, MCA, the governing body will not grant final approval of the subdivision until the subdivider obtains a license for the facility from the Montana Department of Public Health and Human Services under Title 50, Chapter 52, MCA
- iv. The governing body shall not grant final approval until the applicant has met all the requirements of the Montana Department of Environmental Quality (MDEQ) in Title 76, Chapter 4, MCA and/or Title 50, Chapter 60, MCA as applicable.

## **VII-B. Design Standards for Subdivision Providing Multiple Spaces for Rent or Lease**

### **VII-B-1. General Design Standards for Mobile Home Parks and Recreational Vehicle Parks**

- a. Subdivisions providing multiple spaces for rent or lease must comply with the provisions of Section VI as applicable.
- b. The governing body may require provisions for:
  - i. storage facilities on the lot or in compounds located within a reasonable distance;
  - ii. a central area for storage or parking of oversized vehicles, boats, trailers, or other recreational vehicles;
  - iii. landscaping and/or fencing to mitigate impacts of the development on adjacent properties;
  - iv. an off-street area for mail delivery;
  - v. designation of routes for pedestrians and bicycles;
  - vi. appropriate signage within the park;

- vii. setbacks from adjacent property lines or landscaping/fencing to mitigate impacts from natural hazards located within or adjacent to the park;
  - viii. street lighting;
  - ix. location-specific provisions to protect the public health and safety of park occupants; and
  - x. snow storage/removal, if applicable.
- c. Street requirements for Mobile Home/Manufactured Parks and Recreational Vehicle Parks
- i. Streets within mobile or manufactured home parks or recreational vehicle parks must meet the design standards specified in Section VI-F Streets and Roads unless otherwise specified in this section.
  - ii. All streets within mobile or manufactured home parks or recreational vehicle parks shall be private.
  - iii. Streets must be designed to provide safe access to public roads.
  - iv. Streets shall be designed to provide access to all sites. No site shall have vehicular access to a public street. The streets shall be laid out to discourage through traffic and intersections with public streets shall be kept to a minimum.
  - v. Streets within mobile or manufactured home parks or recreational vehicle parks must be designed to provide safe traffic circulation and parking.
  - vi. All traffic control devices used shall comply with the current edition of the Manual of Uniform Traffic Control Devices (MUTCD).
  - vii. Street Width
    - 1. One-way roads must be at least 15 feet wide;
    - 2. Two-way roads must be at least 24 feet wide.

## **VII-B-2. Design Standards for Mobile/Manufactured Home Parks**

- a. Mobile/Manufactured Home Spaces
- i. Mobile/manufactured home spaces must be arranged to permit the safe and practical placement and removal of mobile homes.
  - ii. All mobile/manufactured homes must be located at least 25 feet from any property boundary line abutting upon a public street or highway right-of-way and at least 15 feet from other boundary lines of the park.
  - iii. The mobile/manufactured home pad must be located at least 10 feet from the street that serves it.

- iv. The size of the mobile/manufactured home pad must be suitable for the general market to be served and must fit the dimensions of mobile/manufactured homes anticipated.
- v. A mobile/manufactured home pad may not occupy more than one-third (1/3) of the area of its space. The total area occupied by a mobile home and its roofed accessory buildings and structures may not exceed two-thirds (2/3) of the area of a space.
- vi. No mobile/manufactured home or its attached structures, such as awnings and carports, may be located within a minimum of 20 feet from any other mobile home or its attached structures.
- vii. No detached structure, such as a storage shed, may be located within a minimum of five (5) feet of any mobile/manufactured home or its attached structures.
- viii. A minimum of two off-street parking spaces must be provided on or adjacent to each mobile/manufactured home space.
- ix. One guest parking space must be provided for each 10 mobile/manufactured home spaces. Group parking may be provided.

### **VII-B-3. Design Standards for Recreational Vehicle Parks**

#### **a. Space and Pad Layout**

- i. Recreational vehicles must be separated from each other by at least 20 feet. Any structure or part of a structure attached to the vehicle such as attached awnings must, for purposes of this separation requirement, be considered part of the recreational vehicle.
- ii. All recreational vehicles must be located at least 25 feet from any property boundary line abutting upon a public street or highway right-of-way and at least 15 feet from other boundary lines of the park.

#### **b. Parking Requirements**

- i. Each space must show one parking area with a minimum dimension of 9 feet by 18 feet.
- ii. Parking areas must be setback from the street by a minimum of 4 feet.
- iii. Additional parking and storage areas must meet the same setbacks as the recreational vehicle spaces.

## **VIII. CONDOMINIUMS, TOWNHOMES OR TOWNHOUSES**

---

### **VIII-A. Exemptions**

- a. All condominiums, townhomes, or townhouses or conversions developments are subdivisions subject to the terms of these Regulations and the Montana Subdivision and Platting Act (MSPA), except those exempted by Section 76-3-203, MCA, as described below:
  - i. The approval of the original subdivision of land expressly contemplated the construction of the condominiums, townhomes, or townhouses or conversions and any applicable park dedication requirements in Section 76-3-621, MCA are complied with; or
  - ii. The condominium, townhome, or townhouse or a conversion proposal is in conformance with applicable local zoning regulations when local zoning regulations are in effect.

### **VIII-B. Procedures**

- a. All condominiums, townhomes, or townhouses or conversion developments which are not exempt from subdivision review, are subject to the applicable procedures contained in Section II. General Procedures and the Design and Improvement Standards in Section VI. Subdivisions Created for Rent or Lease for submittal requirements, preliminary plat approval and final plat approval.
  - i. All condominiums, townhomes, or townhouses or conversion developments creating five or fewer units must be reviewed according to Section III-A First Minor Subdivisions.
  - ii. All condominiums, townhomes, or townhouses or conversion developments creating more than five units must be reviewed according to Section IV Review and Approval Procedures for Major Subdivisions.
  - iii. All condominiums, townhomes, or townhouses or conversion developments that will expand an existing development resulting in the accumulative total of more than five units must be reviewed according to Section IV Review and Approval Procedures for Major Subdivisions.
  - iv. Any subdivision which will provide multiple spaces for recreational camping vehicles or manufactured or mobile homes which are converted to condominium use must be reviewed pursuant to this Section.

### **VIII-C. Design Standards**

- a. Condominiums, townhomes or townhouses or conversion developments shall comply with those standards contained in Section VI. Design and Improvement Standards.
- b. Condominiums, townhomes, and townhouses or conversion developments shall comply with all applicable provisions of the Unit Ownership Act – Condominiums, Title 70, Chapter 23, MCA, as amended.

- c. No structure containing a condominium, townhome or townhouse unit shall extend across a property line.

DRAFT

# **IX. DIVISIONS OF LAND EXEMPT FROM SUBDIVISION REVIEW**

## **IX-A. Purpose**

The MSPA provides miscellaneous exemptions for some divisions of land, which are found in Part 2 of Title 76, Chapter 3, MCA. These divisions are exempt from local subdivision review and approval and are therefore not subject to the review requirements or design standards of these regulations. However, pursuant to Section 76-3-504 (1)(p), MCA local subdivision regulations, must, at a minimum, establish criteria that the governing body or reviewing authority will use to determine whether proposed methods of disposition, using the exemptions provided in Section 76-3-201 or 76-3-207, MCA, are attempts to evade the MSPA. This Section establishes those criteria and the administrative processes for examination of exempt divisions of land.

## **IX-B. Exemption Examination Process**

### **IX-B-1. General Submittal and Administrative Procedures**

#### **a. Submittal Requirements**

A landowner(s) (“claimant” herein) claiming an exemption listed under Section IX-C shall submit a draft certificate of survey, amended plat or, where a survey is not required, a draft instrument of conveyance and evidence of entitlement to the claimed exemption to the planner for examination. Additional submittal requirements specific to certain types of exemptions are listed in Section IX-B-1 AND IX-C.

Three copies of the complete application are to be submitted to the Clerk and Recorder, along with the Exemption Review fee. Each application must contain the following:

- i. As required, a certificate of survey in either draft or final form.
- ii. A completed Exemption Review Application (Appendix 22), including signatures of all landowners.
- iii. Supporting documents or evidence of entitlement to the claimed exemption, including all applicable plats or surveys.

#### **b. Review by Exemption Review Board**

- i. The Clerk and Recorder shall distribute the exemption request materials to the exemption review board. The landowner requesting the exemption shall be notified by the clerk and recorder in advance of the exemption review board meeting. In accordance with the Montana open meeting law, exemption review board meetings shall be properly noticed. The exemption review board shall meet to review the proposed exemption.
- ii. The Exemption Review Board shall review the document(s) and may consult with the County Attorney, Examining Land Surveyor, and other staff and officials (e.g., the Montana DEQ, Department of Revenue, etc.). Additional copies of document(s) may be required for other city/county departments for comment and suggested corrections, if necessary.

- iii. The exemption shall be examined to determine whether it complies with the requirements set forth in this chapter, the MSPA, and the Montana Sanitation in Subdivisions Act and approved or denied within twenty (20) working days of the receipt of an application containing all the materials and information. The Exemption Review Board shall make the determination in writing, explaining the reasons for the determination.
  - iv. No conditions may be imposed on the approval except for conditions necessary to ensure compliance with the survey requirements of Title 76, Chapter 3, part 4.
  - v. If the Exemption Review Board finds that the proposed use of the exemption complies with the statutes and applicable criteria, the County Clerk and Recorder will inform the applicant that the applicable document(s) may be filed. If the Exemption Review Board finds the proposed use of the exemption does not comply with the statutes and the criteria in this chapter, the Clerk and Recorder shall advise the applicant of the decision in writing.
  - vi. After review and approval of the applicable document(s) by the Exemption Review Board, and when all appropriate signatures are in place, the proper documents shall be filed with the Clerk and Recorder's Office within one calendar year of the notification from the Exemption Review Board that the applicable document(s) may be filed. An extension may be granted by the Clerk and Recorder if all circumstances surrounding the exemption are the same as when the exemption was approved.
  - vii. If the use of an exemption is denied, the claimant may initiate the process to apply for subdivision review subject to the requirements of these subdivision regulations and other applicable regulations or appeal the Exemption Review Board's decision to the governing body.
- c. Appeals
- i. A claimant whose proposed use of exemption has been denied by the Exemption Review Board may appeal the decision to the governing body. The appeal request shall be submitted in writing to the Clerk and Recorder with ten (10) working days. The claimant may submit additional evidence to show that the use of the exemption in question is appropriate and not intended to evade the MSPA. The planner shall then prepare and submit a staff report and applicable materials to the governing body for its consideration.
  - ii. If the governing body (at a duly noticed public meeting or public hearing held within 20 working days) concludes that the evidence and information demonstrate that the exemption is not being invoked to evade the MSPA or otherwise finds the exemption appropriate, the governing body shall authorize the use of the exemption in writing. A survey claiming such an exemption from subdivision review (or an instrument of conveyance if no survey is required), which otherwise is in proper form and approved by the Examining Land Surveyor, may be filed if it is accompanied by the written authorization of the governing body.
  - iii. If the governing body determines that the proposed use of an exemption was for the purpose of evading the MSPA or these regulations, the claimant proposing to use the exemption may submit a subdivision application for the proposed land division.

## **IX-B-2. Exemption Review Criteria**

- a. When determining whether an exemption is claimed for the purpose of evading the MSPA, the planner (and governing body when considering appeals), shall consider all the surrounding circumstances. These circumstances may include but are not limited to:
  - i. the nature of the claimant's business,
  - ii. the prior history of the tract in question (the tract of record on file at the County Clerk & Recorder Office filed prior to July 1, 1974),
  - iii. the proposed configuration of the tracts if the proposed exempt transaction(s) is completed,
  - iv. and any pattern of exempt transactions that will result in the equivalent of a subdivision without local government review. [*State ex rel. Dreher v. Fuller*, 849 P.2d 1045 (1993)]
- b. Exempt divisions of land that would result in a pattern of development equivalent to a subdivision may be considered to be adopted for purposes of evading the MSPA based on the surrounding circumstances in Subsection (a), above.
- c. When determining whether an exemption is claimed for the purpose of evading the MSPA, the planner (and governing body when considering appeals), shall consider the criteria for review outlined for the specific exemptions listed in Section IX-C below.

## **IX-B-3. General Requirements for Exemptions**

- a. All parcels and the use of all parcels created or amended using an exemption shall comply with any applicable zoning regulations.
- b. The local jurisdiction may not require lots resulting from exempt divisions to comply with Section VI, Design and Improvement Standards, unless the exemption seeks to alter a lot that was subject to the design and improvement standards of the subdivision regulations during subdivision review.
- c. To exempt divisions and/or remaining parcels of land resulting from the exemptions in Section 76-3-207, MCA from the survey requirements of MCA 76-3-401, the parcel(s) must be able to be described as a 1/32 or larger aliquot part of a United States Government section.
- d. Subject to the following, a division of land exempt from subdivision review by Section 76-3-207, MCA (family transfers, agricultural exemptions, relocation of common boundaries, or aggregations) may not be made unless the County Treasurer has certified that all real property taxes and special assessments assessed and levied on the land to be divided have been paid.
  - i. If a division of land includes centrally assessed property and the property taxes applicable to the division of land are not specifically identified in the tax assessment, the department of revenue shall prorate the taxes applicable to the land being divided on a reasonable basis. The owner of the centrally assessed property shall ensure that the prorated real

property taxes and special assessments are paid on the land being sold before the division of land is made.

- ii. The County Treasurer may accept the amount of the tax prorated pursuant to the above subsection as a partial payment of the total tax that is due.

### **IX-C. Requirements for Specific Exemptions**

#### **IX-C-1. Gift or Sale to a Member of the Immediate Family [Section 76-3-207 (1)(b), MCA]:**

Divisions made outside of platted subdivisions for the purpose of a single gift or sale in each county to each member of the landowner's immediate family.

##### a. Statement of Intent

The intent of this exemption is to allow a landowner to create one parcel for conveyance to each immediate family member without local subdivision review.

##### b. Requirements

- i. This exempt division may only be made outside of any platted subdivision unless the following criteria are met:
  - 1. the exempt division complies with adopted zoning for the subdivision;
  - 2. is within a subdivision that has been approved by the governing body;
  - 3. creates parcels of a size allowed within the subdivision;
  - 4. an amended plat pursuant to Section II-B-6 is filed with the county clerk and recorder; and
  - 5. the amended plat states that a restriction or requirement on the platted subdivision continues to apply to the division.
- ii. Only one parcel may be conveyed to each immediate family member of the landowner under this exemption in each county where the landowner owns property. A conveyance outside a platted subdivision may be owned jointly with that immediate family member's spouse.
- iii. For purposes of this exemption, "immediate family member" means a spouse, child by blood or adoption, or parent of the grantor.
- iv. This exemption may only be used when the grantors and grantees are natural persons and not entities such as corporations, partnerships, and trusts.
- v. Filing of any certificate of survey (or recording of an instrument of conveyance) that would use this exemption must show the name of the grantee, relationship to the landowner, and

the parcel to be conveyed under this exemption, and the landowner's certification of compliance [ARM 24.183.1104 (1)(f)(ii) found in Appendix A].

- vi. Any certificate of survey that would use this exemption shall be accompanied by the instrument of conveyance, such as a deed.
- vii. A conveyance outside a platted subdivision may be made regardless of age. If the transfer is to a minor, the transfer must be in accordance with the Uniform Transfer to Minors Act and appropriate documentation must be provided. [Section 72-26-603, MCA]
- viii. A division of land outside of a platted subdivision that is also located in a zoning district is allowed if each exemption is at least 5 acres, unless the zoning district allows for smaller lot sizes.
- ix. An immediate family member or the spouse of an immediate family member may not transfer or otherwise convey the division of land for a period of up to 2 years after the date of the division unless the governing body sets a period of less than 2 years. The immediate family member or spouse must sign a statement that they will not convey the division for the period of years which shall be filed with the certificate of survey, amended plat or aliquot part division deed.
- x. The immediate family member or spouse may request a variance from holding the division for a period of years to address hardship situations such as:
  - 1. death of the immediate family member or spouse; or
  - 2. medical emergency.

c. Criteria for Review

- i. Whether the proposed use of a family transfer exemption is to divide a tract of record that was created through use of an exemption. This is in effect regardless of previous ownership of the tracts and pertains to remaining tracts of less than 160 acres as well as to those tracts that were created through the exemptions.
- ii. Whether the proposed use of a family transfer exemption is to divide a tract that was created as part of an overall development plan with such characteristics as common roads, utility easements, open space or common marketing or promotional plan.
- iii. Whether the proposed use of a family transfer exemption was preceded by a transfer of a parcel of land by one or more family members to another, to prepare for a qualifying family transfer, followed by the attempted use of this exemption.
- iv. Whether the proposed use of a family transfer exemption would create more than one remaining parcel of less than 160 acres.

d. Enforcement

If a governing body can prove by documented evidence in a court of competent jurisdiction that a person has knowingly evaded subdivision review for a family transfer within or outside a platted subdivision, that person is subject to a civil penalty of \$5,000 for each division of land, payable to the governing body.

**IX-C-2. Divisions of Land for Agricultural Use Only** [Section 76-3-207 (1)(c), MCA]

Divisions made outside of platted subdivisions by gift, sale, or agreement to buy and sell in which the parties to the transaction enter a covenant running with the land and that the divided land will be used exclusively for agricultural purposes. If the divided land is used for anything other than agricultural purposes, the land must go through subdivision review.

a. Statement of Intent

The intent of this exemption is to allow a landowner to create a parcel without local subdivision review where the parcel will be used only for production of livestock or agricultural crops and no residential, commercial, or industrial buildings, which require water or sewer, will be constructed on the parcel.

b. Requirements

- i. For purposes of this exemption, the term “agricultural purposes” means the use of land for raising crops or livestock, or for the preservation of open space, and specifically excludes residential, commercial, and industrial uses and structures, as well as any facilities for commercially or industrially processing agricultural products.
- ii. The division must be located outside any platted subdivision.
- iii. The division must be exempt from sanitation review by the MDEQ pursuant to Section 76-4-125 (2)(c), MCA, as a division made for purposes other than the construction of water supply or sewage and solid waste disposal facilities. This sanitation exclusion must be properly invoked by the property owner on the certificate of survey (or instrument of conveyance).
- iv. A certificate of survey (or instrument of conveyance) that uses this exemption requires a covenant running with the land in accordance with Section 76-3-207 (1)(c), MCA, and a signed and acknowledged recitation of the covenant on the face of the survey (or conveyance document) [ARM 24.183.1104 (1)(f)(i), refer to Appendix A].
- v. Any change in use of the newly created agricultural parcel for anything other than agricultural purposes subjects the parcel to subdivision review. Residential, commercial, or industrial structures, including facilities for commercial processing of agricultural products, may not be utilized, constructed, or erected on parcels created under this exemption unless the covenant is revoked through subdivision review.

c. Criteria for Review

- i. Whether the proposed use of an agricultural exemption is to divide a tract of record that was created through use of an exemption. This is in effect regardless of previous ownership of the tracts and pertains to remaining tracts of less than 160 acres as well as to those tracts that were created through the exemptions.
- ii. Whether the proposed use of an agricultural exemption is to divide a tract that was created as part of an overall development plan with such characteristics as common roads, utility easements, open space or common marketing or promotional plan.
- iii. Whether the proposed use of an agricultural exemption would create more than one remaining parcel of less than 160 acres.

d. Removal

Removal of the agricultural covenant according to Section 76-3-211, MCA; or,

- i. The governing body may, in its discretion, approve the removal of the agricultural covenant without subdivision review if:
  - 1. The original lot lines are restored through aggregation of the covenanted tract prior to, or in conjunction with, the lifting of the agricultural covenant; or
  - 2. The proposed lifting of the covenant is for a government or public entity seeking to use the tract for public purposes. Public purposes are defined for the purposes of this section as utility stations, airports, cemeteries, water and/or wastewater facilities.
    - a) The governing body shall determine the qualifications and purpose of the public entity, by the following:
      - 1) holding a public hearing as set forth in Section I-F;
      - 2) considering the information and evidence provided at the public hearing;
      - 3) issuing written findings of fact based on the information and evidence within 15 working days; and
      - 4) either approving or denying the removal of the agricultural covenant.
- ii. An Agricultural Exemption Removal agreement lifting the agricultural covenant shall be recorded at the office of the County Clerk and Recorder.
- iii. The revocation of an Agricultural Covenant Exemption does not affect sanitary restrictions imposed under Title 76, Chapter 4, MCA.

**IX-C-3. Relocation of Common Boundaries and Aggregation of Lots** [Section 76-3-207 (1)  
(a), (d), (e), and (f), MCA]

a. Statement of Intent

The intent of these exemptions is to allow a change in the location of one or more boundary line between parcels and to allow transfer of the land without subdivision review or to allow more than one parcel to be aggregated into fewer parcels.

b. Requirements

- i. If the relocation of common boundaries would result in the permanent creation of an additional parcel of land, the division of land must be reviewed as a subdivision.
- ii. If a change is made to a platted subdivision which results in a redesign or rearrangement of six or more lots in a platted subdivision, the division of land must be reviewed as a major subdivision.
- iii. If the relocation of common boundaries would result in the creation of a new lot in a platted subdivision, the relocation must be reviewed as an amendment to a final platted subdivision.
- iv. Certificates of survey or amended plats for those altering platted subdivisions, claiming one of these exemptions must clearly distinguish between existing boundary locations and new boundary locations. This shall be accomplished by showing the existing boundaries with dashed lines and the new boundaries with solid lines. The appropriate certification set forth in ARM 24.183.1104 (1)(f) must be included on the certificate of survey or amended plat.
- v. Any restriction or requirement on the original platted lot or original unplatted parcel continues to apply to those areas.

c. Criteria for Review

- i. Whether the resulting lots are inconsistent with an approved subdivision and the uses in it.
- ii. Whether the documentation submitted does or does not support the stated purpose for the relocation;
- iii. Whether the proposed relocation creates a parcel of less than 160 acres which, prior to the relocation included more than 160 acres.

**IX-C-4. Exemption to Provide Security for a Construction Mortgage, Lien or Trust Indenture**  
[Section 76-3-201 (1)(b), MCA]

If a parcel of land was divided using this exemption and one of the parcels created by the division was conveyed by the landowner to another party without foreclosure before October 1, 2003, the conveyance of the remaining parcel is not subject to the requirements of Parts 5 and 6 of the MSPA and the subdivision review processes of these regulations.

a. Statement of Intent

The intended purpose of this exemption is to allow a claimant who is buying a tract using financing or a contract for deed to segregate a smaller parcel from the tract for security for financing construction of a home on the property. No tract of land is created unless there is a default by the claimant to the lending institution.

b. Use of Exemption

- i. This exemption is not available to simply create a parcel without review by claiming that the parcel will be used for security to finance construction of a home or other structure on the proposed lot.
- ii. This exemption may not be properly invoked unless:
  1. The claimant is purchasing a larger tract through financing or a contract for deed (and thus does not hold title); and
  2. A lending institution requires the claimant to hold title to a smaller parcel of the tract because the smaller tract is required as security for a building construction loan.

c. Requirements

- i. These regulations do not require a certificate of survey or amended plat to invoke the use of the exemption claimed under Section 76-3-201 (1)(b), MCA. Surveys for this exemption are at the discretion of the claimants, lending institutions, surveyors, etc., but are encouraged to provide proper legal descriptions in the event of default of the lien and creation of the tract(s).
- ii. When this exemption is to be used, the claimant shall submit the following along with an affidavit affirming entitlement to the claimed exemption to the planner:
  1. A statement of how many parcels within the original tract would be created by use of the exemption;
  2. A signed statement from a lending institution that the creation of the exempted parcel is necessary to secure a construction loan for buildings or other improvements on the parcel; and
  3. Documentation that the lending institution is a financial or lending institution registered to do business in the State of Montana.

d. Criteria for Review

- i. Whether the exemption will create more than one building site;
- ii. Whether the financing is not for construction on the exempted parcel, or for re-financing;

- iii. Whether the person named in the statement explaining who will have possession of the remainder parcel if title to the exempted parcel is created through a default to the lending institution is anyone other than the borrower of funds for construction;
- iv. Whether there is an existing prior agreement to default or a prior agreement to purchase only a portion of the original tract;
- v. Whether title to the exempted parcel will not be initially obtained by the lending institution if foreclosure occurs;
- vi. Whether it appears that the principal reason the parcel is being created is to create a building site and using the parcel to secure a construction loan is a secondary purpose; or
- vii. Whether the division of land is created for the purpose of conveyance to any entity other than the financial or lending institution to which the mortgage, lien or trust indenture was given, or to a purchaser upon foreclosure of the mortgage, lien, or trust indenture.

**IX-C-5. Division for Rights-of-way or Utility Site** [Section 76-3-201 (1)(h), MCA]

a. Statement of Intent

The intent is to create rights-of-way or utility sites. Utility is defined in Section 69-3-101, MCA. Rights-of-way for land dedication for city, county roads or other transportation systems may require land dedications rather than easements. A subsequent change in the use of the land to a residential, commercial, or industrial use is subject to the requirements of the MSPA and subdivision review under these regulations.

b. Requirements

- i. Landowner approval or proof of eminent domain authority by the entity acquiring the right-of-way.
- ii. Documentation to be filed shall include a notarized statement from the recipient accepting the right-of-way, stating the purpose of the right-of-way, and noticing that under Section 76-3-201, MCA a subsequent change in the use to residential, commercial, or industrial subjects the division to review under the MSPA and subdivision review under these regulations.
- iii. Any certificate of survey that would use this exemption shall be accompanied by the instrument of conveyance, such as a deed.

c. Criteria for Review

- i. Whether the proposed exemption is for a right-of-way or utility site.
- ii. Whether the entity to which the right-of-way is being transferred is for a city, county roads or other transportation systems, or the entity for which a utility site is created does meet the definition of a utility per Section 69-3-101, MCA.

**IX-C-6. Court Ordered Divisions** [Section 76-3-201 (1)(a), MCA]

- a. The intent of this exemption is to provide for divisions of land created by order of any court of record in this state or by operation of law or that, in the absence of agreement between the parties to the sale, could be created by an order of any court in this state pursuant to the law of eminent domain, Title 70, Chapter 30, MCA.
- b. Pursuant to Section 76-3-201 (2), MCA, before a court of record orders a division of land, the court shall notify the governing body of the pending division and allow the governing body to present written comments on the division.
- c. A court ordered division of land is not a subdivision under this chapter if no more than four new lots or parcels are created from the original lot or parcel. If more than four new lots or parcels are created, the division must go through subdivision review under these regulations.

**IX-C-7. Condominiums, Townhomes, or Townhouses** [Section 76-3-203, MCA]

a. Statement of Intent

Generally, condominiums, townhomes, or townhouses, or conversion as those terms are defined in Section 70-23-102, MCA are subject to review as subdivisions, but under certain circumstances they may be exempt from review pursuant to Section 76-3-203, MCA.

b. Use of the exemption

- i. Condominiums, townhomes, or townhouses, or conversion as those terms are defined in Section 70-23-102, MCA are exempt from subdivision review if:
  - 1. They are constructed on lots subdivided in compliance with these regulations and the approval of the original subdivision of land expressly contemplated the construction of the condominiums, townhomes, or townhouses or conversion and any applicable park dedication requirements in Section 76-3-621, MCA and Section VI-O of these regulations are complied with; or
  - 2. The condominium, townhome, or townhouse or conversion proposal is in conformance with applicable local zoning regulations pertaining to land use, density, bulk and dimensional requirements, landscaping and parking requirements when local zoning regulations are in effect.
  - 3. The governing body may not enact regulations prohibiting the townhome form of ownership or impose conditions on a determination that the condominium, townhome, townhouse or conversion proposal and may not require the condominium, townhome, townhouse or conversion proposal to undergo a conditional use permit or other quasi-judicial governmental review process adopted pursuant to zoning regulations as a prerequisite to determining the eligibility for an exemption.

c. Requirements

- i. To use the exemption, the Declaration of Unit Ownership must include an exhibit containing certification from the planner or governing body that the condominiums are exempt from review under Section 76-3-203, MCA (See Section 70-23-301, MCA).
- ii. Only the local government has the authority to determine whether a division of land is exempt from subdivision review. The act of recording a condominium declaration does not establish the declaration's validity simply because the County Clerk and Recorder's Office accepted and recorded it.
- iii. To obtain certification from the planner that the condominiums, townhomes, or townhouses or conversion are exempt from review as a subdivision, the person seeking the use of the exemption shall submit evidence of and an affidavit affirming entitlement to the exemption to the planner, who will review the documents as required under the exemption review process; however, an exemption claimed pursuant to Section 76-3-203, MCA is not subject to examination under the Exemption Evasion Criteria.

**IX-C-8. Exemptions Not Requiring Action by the Planner/Subdivision Administrator**

If a survey is to be filed with the County Clerk and Recorder's Office to utilize any of the exemptions not subject to action by the planner, the survey is subject to examination by the Examining Land Surveyor for compliance with the uniform standards adopted under Appendix A of these regulations. These exemptions are as follows:

- a. A division of land created by lease or rental of contiguous airport-related land owned by a city, a county, the state, or a municipal or regional airport authority is not subject to the subdivision review requirements of this chapter or the MSPA, provided that the lease or rental is for onsite weather or air navigation facilities, the manufacture, maintenance, and storage of aircraft, or air carrier-related activities. [Section 76-3-205 (1), MCA]
- b. A division of state-owned land is not subject to the subdivision review requirements of this chapter or the MSPA unless the division creates a second or subsequent parcel from a single tract for sale, rent, or lease for residential purposes after July 1, 1974. [Section 76-3-205 (2), MCA]
- c. Deeds, contracts, leases, or other conveyances which were executed prior to July 1, 1974. [Section 76-3-206, MCA]
- d. State Highways: Instruments of transfer of land which is acquired for state highways may refer by parcel and project number to state highway plans which have been recorded in compliance with Section 60-2-209, MCA and are exempted from the surveying and platting requirements of the MSPA and these regulations. If such parcels are not shown on highway plans of record, instruments of transfer of such parcels shall be accompanied by and referred to appropriate certificates of survey and plats when presented for recording. A survey or plat for the recordation of an instrument transferring title to a remainder that was created when the state obtained property for a highway right-of-way is not required. [44 A.G. Opinion 25 (1992)]

- e. The following divisions in Section 76-3-201, MCA not previously included in this section:
  - i. A division of land that creates an interest in oil, gas, minerals, or water that is severed from the surface ownership of real property;
  - ii. A division of land that creates cemetery lots;
  - iii. A division of land that is created by the reservation of a life estate;
  - iv. A division of land that is created by lease or rental for farming and agricultural purposes;  
and
  - v. A division of land that is in a location over which the state does not have jurisdiction.

### **IX-C-9. Identification Codes**

To assist in the implementation of this review process and to monitor those parcels by exemption the Clerk and Recorder may cause the following identification codes to be added to the numbering of recorded certificates of survey filed after the effective date of these regulations.

- CO ... Court Order [76-3-201 (1)(a), MCA]
- ME ... Mortgage Exemption [76-3-201 (1)(b), MCA]
- LE ... Life Estate [76-3-201 (1)(e), MCA]
- BA ... Relocation of Common Boundary [76-3-207 (1)(a), MCA]
- FC ... Family Conveyance [76-3-207 (1)(b), MCA]
- AE ... Agricultural Exemption [76-3-207 (1)(c), MCA]
- OS ... Occasional Sale (used prior to April 6, 1993)
- AL ... Aggregation of Lots [76-3-207 (e), MCA]
- US ... Utility Site [76-3-201 (1)(h), MCA]
- ROW ... Rights-of-Way [76-3-201 (1)(h), MCA]

# APPENDIX 1: UNIFORM STANDARDS FOR MONUMENTATION, CERTIFICATES OF SURVEY, AND FINAL SUBDIVISION PLATS

---

## ARM 24.183.1101 UNIFORM STANDARDS FOR MONUMENTATION

- (1) The following standards govern the monumentation of land surveys:
- (a) The terms "monument" and "permanent monument" as used in these regulations mean any structure of masonry, metal, or other permanent, durable material placed in the ground, which is exclusively identifiable as a monument to a survey point, expressly placed for surveying reference.
  - (b) All metal monuments must be at least one-half inch in diameter and 18 inches in length with a cap not less than one inch in diameter marked in a permanent manner with the license number of the surveyor in charge of the survey and either the name of the surveyor or the company employing the surveyor. Metal monuments marking a public land survey corner as described in 70-22-101, MCA, must be at least 24 inches long and 5/8 inch in diameter with an appropriately stamped metal cap at least two inches in diameter. A monument marking a public land survey corner may also consist of a cap as described in this rule set firmly in concrete.
  - (c) Before a subdivision plat or certificate of survey may be filed for record, the surveyor shall confirm the location of as many monuments as, in the surveyor's professional judgment, are necessary to reasonably assure the perpetuation of any corner or boundary established by the survey and to enable other surveyors to reestablish those corners and boundaries and retrace the survey. The surveyor shall clearly identify on the face of the plat or certificate of survey all monuments pertinent to the survey, and the descriptions of these monuments must be sufficient to identify the monuments.
  - (d) The surveyor shall set all monuments prior to the filing of a plat or certificate of survey, except those monuments that will be disturbed by the installation of improvements, or because of severe weather conditions, may, in the surveyor's judgment, be more appropriately and accurately set after the weather has improved. In these two circumstances the surveyor may set monuments after the survey document is filed if the surveyor certifies on the survey document that the monuments will be set by a specified date. The surveyor shall set monuments, the placement of which has been deferred because of severe weather conditions, within 240 days of the date on which the survey document was filed.
    - (i) If during the later monumentation of the corners of a plat or certificate of survey that were not monumented before the plat or certificate was filed, the surveyor finds that it is necessary to set a reference monument to a corner, the surveyor shall prepare and file an amended certificate of survey or subdivision plat.
    - (ii) The failure of the surveyor to set the monuments by the date certified on the record of survey will be deemed a violation of these rules.
  - (e) The surveyor shall set monuments at the following locations:
    - (i) at each corner and angle point of all lots, blocks and parcels of land created by the survey;
    - (ii) at every point of intersection of the outer boundary of a subdivision with an existing road right-of-way line of record or a road right-of-way line created by the survey;
    - (iii) at every point of curve, point of tangency, point of reversed curve, point of compounded curve and point of intersection on each road right-of-way line created by the survey; and
    - (iv) at the intersection of a boundary line and a meander line. Meander line angle points need not otherwise be monumented.

- (f) If the placement of a required monument at its proper location is physically impractical, the surveyor may set a reference or witness monument. This monument has the same status as other monuments of record if its location is properly shown. If the surveyor relies upon any existing monument in conducting a survey, he or she shall confirm the location of the monument and show and describe it on the resulting certificate of survey or subdivision plat.
- (g) If the land surveyor sets a monument that is on, is a part of, and controls a property line, then the surveyor shall file a certificate of survey which complies with the requirements of ARM 24.183.1104. Alternatively, the surveyor may file a corner record in lieu of a certificate of survey pursuant to 70-22-105(2), MCA.

(2) Remonumentation of public land survey corner monuments shall conform to ARM 24.183.1002.

#### **24.183.1104 UNIFORM STANDARDS FOR CERTIFICATES OF SURVEY**

- (1) A certificate of survey must comply with the following requirements:
  - (a) A certificate of survey must be legibly drawn with permanent black ink or printed or reproduced by a process guaranteeing a permanent record and must be 18 inches by 24 inches or 24 inches by 36 inches. Margins must be a minimum 1/2-inch on all sides, or as required by the filing office.
  - (b) One original on three mil or heavier matte stable-base polyester film or equivalent and/or one original on 24# white bond paper or equivalent must be submitted, or on such medium as required by the filing office.
  - (c) If more than one sheet must be used to adequately depict the land surveyed, each sheet must show the number of that sheet and the total number of sheets included. All certifications must be placed on sheet number one of the certificate of survey.
  - (d) A certificate of survey must show or contain the following information:
    - (i) a title or title block including the quarter-section, section, township, range, principal meridian, county, and if applicable, city or town in which the surveyed land is located. Except as provided in (1)(f)(v), a certificate of survey must not contain the title "plat," "subdivision," or any title other than "Certificate of Survey";
    - (ii) the name(s) of the person(s) who commissioned the survey, the name(s) of the owner(s) of the land surveyed, if other than the person(s) commissioning the survey, the names of any adjoining plats, and the numbers of any adjoining certificates of survey previously filed;
    - (iii) the date the survey was completed and a brief explanation of why the certificate of survey was prepared, such as to create a new parcel, retrace a section line, or retrace an existing parcel of land;
    - (iv) a north arrow;
    - (v) a scale bar. The scale of the certificate of survey must be sufficient to legibly represent the required information and data on the certificate of survey;
    - (vi) the location of, and other information relating to all monuments found, set, reset, replaced, or removed as required by ARM 24.183.1101;
      - (a) If additional monuments are to be set after the certificate of survey is filed, the location of these monuments must be shown by a distinct symbol, and the certificate of survey must contain a certification by the land surveyor as to the reason the monuments have not been set and the date by which they will be set, as required by ARM 24.183.1101(1)(d).

- (b) All monuments found during the survey that influenced the position of any corner or boundary indicated on the certificate of survey must be clearly shown as required by ARM 24.183.1101(1)(c).
- (c) Witness and reference monuments must be clearly shown.
- (vii) the location of any section corner or corners of divisions of sections the land surveyor deems to be pertinent to the survey or was used as a control in the survey;
- (viii) basis of bearing. For purposes of this rule, the term "basis of bearing" means the land surveyor's statement as to the origin of the bearings shown on the certificate of survey. If the basis of bearing(s) refers to two previously monumented points in a previously filed survey document, then the two previously monumented points must be shown and described on the certificate of survey, the line marked by the two previously monumented points must be labeled "basis of bearing," and the previously filed survey document name or number must be cited in the land surveyor's statement as to the origin of the bearing(s). If the certificate of survey shows true bearings, the basis of bearing must describe the method by which these true bearings were determined;
- (ix) the bearings, distances, and curve data of all boundary lines and all control or pertinent lines used to determine the boundaries of the parcel(s) surveyed. If the parcel surveyed is bounded by an irregular shoreline or a body of water that is a riparian boundary, the bearings and distances of a meander traverse generally paralleling the riparian boundary must be given;
  - (a) The courses along a meander line are shown solely to provide a basis for calculating the area of a parcel that has one or more riparian boundaries as the parcel existed at the time of survey.
  - (b) For purposes of this rule, a line that indicates a fixed boundary of a parcel is not a "meander" or "meander line" and may not be designated as one.
  - (c) If a boundary, control, or pertinent line contains multiple segments of the whole, then the overall distance must be shown, and each segment must at least include distance.
- (x) data on all curves sufficient to enable the reestablishment of the curves on the ground. For circular curves, the data must at least include radius and arc length, and either delta angle, radial bearings, or chord bearing and distance. All non-tangent points of intersection on the curve must show either the bearings of radial lines or chord length and bearing. Non-tangent curves must be so labeled;
- (xi) lengths of all lines shown to at least tenths of a foot, and all angles and bearings shown to at least the nearest minute. Distance measurements must be stated in English units, but their metric equivalents, shown to the nearest hundredth of a meter, may be noted parenthetically;
- (xii) at least one record measurement reference for each line and curve, if available, must be shown;
- (xiii) a narrative legal description of the parcel(s) surveyed.
  - (a) The land surveyor, at his or her discretion, may choose the form of the narrative legal description as follows:
    - (i) If the parcel surveyed is either an aliquot part of a U.S. government section or a U.S. government lot, the narrative legal description may be the aliquot part or the government lot description of the parcel;
    - (ii) If the certificate of survey depicts the division of one or more parcels shown on a previously filed certificate of survey, the narrative legal description may be the number of the previously filed certificate of survey and the parcel number of the parcel(s) previously surveyed;

- (iii) If the certificate of survey depicts the retracement of one or more parcels shown on a previously filed certificate of survey, plat, or amended plat, the narrative legal description may be the number of the previously filed certificate of survey or the name of the previously filed plat or amended plat, and the parcel number of the parcel(s) previously surveyed;
  - (iv) If the survey creates or retraces one or more parcels, the narrative legal description may be either the metes-and-bounds description of each individual parcel created by the survey or the metes-and-bounds description of the perimeter boundary of the parcels surveyed; or
  - (v) If the narrative legal description does not fall within (1)(d)(xiii)(A)(I), (II), or (III), then the narrative legal description required by this subsection must conform with (1)(d)(xiii)(A)(IV).
- (b) When the narrative legal description is metes-and-bounds, the point of beginning, which is also the point of closure of the legal description of the parcel surveyed, must be labeled "Point of Beginning." Alternatively, the point of beginning may be labeled "POB" if the abbreviation is defined on the certificate of survey.
- (c) The requirement of this rule does not apply to certificates of survey that depict a partial retracement of the boundaries of an existing parcel or establish the location of lines or corners that control the location of an existing parcel.
- (xiv) all parcels created or retraced by the certificate of survey designated by number or letter, and the bearings, distances, curve data, and area of each parcel, except as provided in (1)(f)(iii). If a parcel created by the certificate of survey is identifiable as a 1/32 or larger aliquot part of a U.S. government section or as a U.S. government lot, it may be designated by number or letter or by its aliquot part or government lot identification;
  - (xv) the location, bearings, distances, and curve data of any easement that will be created by reference to the certificate of survey;
  - (xvi) the dated signature and the seal of the land surveyor responsible for the survey. The land surveyor's signature certifies that the certificate of survey has been prepared in conformance with the applicable sections of the Montana Subdivision and Platting Act and the regulations adopted under the Act;
  - (xvii) a memorandum of any oaths administered under 76-3-405, MCA;
  - (xviii) if applicable, the certificate of the examining land surveyor; and
  - (xix) space for the clerk and recorder's filing information.
- (e) Certificates of survey that do not represent a division or aggregation of land, such as those depicting the retracement of an existing parcel and those prepared for informational purposes, must contain a statement as to their purpose and must meet applicable requirements of this rule for form and content. If the purpose of a certificate of survey is stated as a retracement or partial retracement, and if multiple tracts of record contained within the parcel's perimeter boundary on the certificate of survey are not individually shown, then the certificate of survey does not expunge the tracts of record unless it conforms to (1)(f)(iv) and contains the acknowledged certificate of the property owner(s) citing the applicable exemption in its entirety.
- (f) Procedures for divisions of land exempted from review as subdivisions. If one or more parcels on a certificate of survey is created by an exemption from subdivision review under 76-3-207, MCA, then, except as provided in (1)(f)(iii) and (iv), the certificate of survey must establish the boundaries of the exemption parcel(s). The certificate of survey is not required to establish, but may establish, the exterior boundaries of the remaining portion of the parent tract of land. However, the certificate of survey must show portions of the existing unchanged boundaries

sufficient to identify the location and extent of the exemption parcel to be created. Unsurveyed portions of the parent tract of land must be labeled, "NOT A PART OF THIS CERTIFICATE OF SURVEY" or "NOT INCLUDED IN THIS CERTIFICATE OF SURVEY". The certificate of survey must contain the acknowledged certificate of the property owner stating that the division of land is exempt from review as a subdivision and cite the applicable exemption in its entirety. The certificate of survey must meet the following requirements:

- (i) If the exemption relied upon requires that the property owner enter into a covenant running with the land, the certificate of survey may not be filed unless it shows or contains a signed and acknowledged recitation of the covenant in its entirety.
- (ii) If a certificate of survey invokes the exemption for gift(s) or sale(s) to members of the landowner's immediate family, the certificate of survey must indicate the name of the proposed grantee, the relationship of the grantee to the landowner, and the parcel to be conveyed to the grantee.
- (iii) If a certificate of survey invokes the exemption for the relocation of common boundary line(s):
  - (a) The certificate of survey must contain the signatures of all landowners whose tracts of record will be altered by the proposed relocation. The certificate of survey must show that the exemption was used only to change the location of a boundary line or lines common to two or more tracts of record, and must clearly distinguish the prior boundary location or locations (shown, for example, by dashed or broken line(s) with a notation) from the new boundary location or locations (shown, for example, by solid line(s) with a notation);
  - (b) The certificate of survey must show the boundaries of the area that is being removed from one tract of record and joined with another tract of record. The certificate of survey is not required to establish, but may establish, the exterior boundaries of the resulting tracts of record. However, the certificate of survey must show portions of the existing unchanged boundaries sufficient to clearly identify both the location and the extent of the boundary relocation. Unsurveyed portions of the tracts of record must be labeled, "NOT A PART OF THIS CERTIFICATE OF SURVEY" or "NOT INCLUDED IN THIS CERTIFICATE OF SURVEY"; and
  - (c) The certificate of survey must contain the following notation: "The area that is being removed from one tract of record and joined with another tract of record is not itself a tract of record. Said area shall not be available as a reference legal description in any subsequent real property transfer after the initial transfer associated with the [certificate of survey or amended plat] on which said area is described, unless said area is included with or excluded from adjoining tracts of record."
- (iv) If a certificate of survey invokes the exemption for aggregation of parcels or lots:
  - (a) The certificate of survey must contain the signatures of all landowners whose tracts of record will be altered by the proposed aggregation. The certificate of survey must show that the exemption was used only to eliminate a boundary line or lines common to two or more tracts of record, and must clearly distinguish the prior boundary location or locations (shown, for example, by dashed or broken line(s) with a notation) from the new perimeter boundary location or locations (shown, for example, by solid line(s) with a notation); and
  - (b) The certificate of survey must establish the perimeter boundary of the resulting tract(s) of record.
- (v) A survey document that modifies lots on a filed plat and invokes an exemption from subdivision review under 76-3-201 or 76-3-207(1)(d), (e), or (f), MCA, must be entitled

"amended plat of [lot, block, and name of subdivision being amended]," but for all other purposes must comply with the requirements for form and descriptive content of certificates of survey contained in this rule.

- (vi) If the certificate of survey invokes an exemption from subdivision review under 76-3-207, MCA, the certificate of survey must contain or be accompanied by a certification by the county treasurer that all real property taxes and special assessments assessed and levied on the surveyed land have been paid.
- (vii) For purposes of this rule, when the parcel of land for which an exemption from subdivision review is claimed is being conveyed under a contract-for-deed, the terms "property owner," "landowner," and "owner" mean the seller of the land under the contract-for-deed.
- (g) The land surveyor, at his or her discretion, may provide additional information on the certificate of survey regarding the survey.
- (h) Procedures for filing certificates of survey of divisions of land entirely exempted from the requirements of the Montana Subdivision and Platting Act. The divisions of land described in 76-3-201, 76-3-205, and 76-3-209, MCA, and divisions of federally owned land made by a U.S. government agency are not required to be surveyed, nor must a certificate of survey or plat showing these divisions be filed with the clerk and recorder. However, a certificate of survey of one of these divisions may be filed with the clerk and recorder if the certificate of survey meets the requirements for form and content for certificates of survey contained in this rule and contains a certificate of all the landowners citing the applicable exemption from the Act in its entirety, or when applicable, that the land surveyed is owned by the federal government. The certificate of survey must establish the boundaries of the exemption parcel(s). The certificate of survey is not required to establish, but may establish, the exterior boundaries of the remaining portion of the parent tract of land. However, the certificate of survey must show portions of the existing unchanged boundaries sufficient to identify the location and extent of the exemption parcel to be created. Unsurveyed portions of the parent tract of land must be labeled, "NOT A PART OF THIS CERTIFICATE OF SURVEY" or "NOT INCLUDED IN THIS CERTIFICATE OF SURVEY."

#### **24.183.1107 UNIFORM STANDARDS FOR FINAL SUBDIVISION PLATS**

- (1) A final subdivision plat must comply with the following requirements:
  - (a) the plat complies with the requirements contained in (2);
  - (b) the plat includes a Conditions of Approval sheet(s) that complies with the requirements contained in (4); and
  - (c) the plat is accompanied by documents listed in (5).
- (2) A plat must comply with the following requirements:
  - (a) A plat must be legibly drawn with permanent black ink or printed or reproduced by a process guaranteeing a permanent record and must be 18 inches by 24 inches or 24 inches by 36 inches. Margins must be a minimum 1/2-inch on all sides, or as required by the filing office.
  - (b) One original on three mil or heavier matte stable-base polyester film or equivalent and/or one original on 24# white bond paper or equivalent must be submitted, or on such medium as required by the filing office.
  - (c) If more than one sheet must be used to adequately depict the land surveyed, each sheet must show the number of that sheet and the total number of sheets included. Except as provided in (4)(b), all certifications must be placed on sheet number one of the plat.

- (d) A survey document that results in an increase in the number of lots or modifies six or more lots on a filed plat must be entitled "amended plat of (lot, block, and name of subdivision being amended)," and unless it is exempt from subdivision review by 76-3-201 or 76-3-207(1)(d), (e), or (f), MCA, must meet the filing requirements for final subdivision plats specified in this rule.
- (e) A plat must show or contain the following information:
  - (i) a title or title block including the quarter-section, section, township, range, principal meridian, county, and if applicable, city or town in which the subdivision is located. The title of the plat must contain the words "plat" and either "subdivision" or "addition";
  - (ii) the name(s) of the person(s) who commissioned the survey, the name(s) of the owner(s) of the land to be subdivided, if other than the person(s) commissioning the survey, the names of any adjoining plats, and the numbers of any adjoining certificates of survey previously filed;
  - (iii) a north arrow;
  - (iv) a scale bar. The scale of the plat must be sufficient to legibly represent the required information and data on the plat;
  - (v) the location of, and other information relating to all monuments found, set, reset, replaced, or removed as required by ARM 24.183.1101;
    - (a) If additional monuments are to be set after the plat is filed, the location of these monuments must be shown by a distinct symbol, and the plat must contain a certification by the land surveyor as to the reason the monuments have not been set and the date by which they will be set, as required by ARM 24.183.1101(1)(d).
    - (b) All monuments found during the survey that influenced the position of any corner or boundary indicated on the plat must be clearly shown as required by ARM 24.183.1101(1)(c).
    - (c) Witness and reference monuments must be clearly shown.
  - (vi) the location of any section corner or corners of divisions of sections the land surveyor deems to be pertinent to the survey or was used as control in the survey;
  - (vii) basis of bearing. For purposes of this rule, the term "basis of bearing" means the land surveyor's statement as to the origin of the bearings shown on the plat. If the basis of bearing(s) refers to two previously monumented points in a previously filed survey document, then the two previously monumented points must be shown and described on the plat, the line marked by the two previously monumented points must be labeled "basis of bearing," and the previously filed survey document name or number must be cited in the land surveyor's statement as to the origin of the bearing(s). If the plat shows true bearings, the basis of bearing must describe the method by which these true bearings were determined;
  - (viii) the bearings, distances, and curve data of all boundary lines and all control or pertinent lines used to determine the boundaries of the subdivision. If the subdivision is bounded by an irregular shoreline or a body of water that is a riparian boundary, the bearings and distances of a meander traverse generally paralleling the riparian boundary must be given;
    - (a) The courses along a meander line are shown solely to provide a basis for calculating the area of a parcel that has one or more riparian boundaries as the parcel existed at the time of survey.
    - (b) For purposes of this rule, a line that indicates a fixed boundary of a parcel is not a "meander" or "meander line" and may not be designated as one.
    - (c) If a boundary, control, or pertinent line contains multiple segments of the whole, then the overall distance must be shown, and each segment must at least include distance.

- (ix) data on all curves sufficient to enable the reestablishment of the curves on the ground. For circular curves, the data must at least include radius and arc length, and either delta angle, radial bearings, or chord bearing and distance. All non-tangent points of intersection on the curve must show either the bearings of radial lines or chord length and bearing. Non-tangent curves must be so labeled;
- (x) lengths of all lines shown to at least tenths of a foot, and all angles and bearings shown to at least the nearest minute. Distance measurements must be stated in English units, but their metric equivalents, shown to the nearest hundredth of a meter, may be noted parenthetically;
- (xi) at least one record measurement reference for each line and curve, if available, must be shown;
- (xii) all lots and blocks in the subdivision designated by number, the bearings, distances, and curve data of each lot and block, the area of each lot, and the total area of all lots. (Excepted lands must be labeled "NOT INCLUDED IN THIS SUBDIVISION" or "NOT INCLUDED IN THIS PLAT";
- (xiii) all existing rights-of-way for streets, alleys, avenues, roads, and highways that adjoin or are within the boundaries of the subdivision; their names and widths from public record (if ascertainable); the bearings, distances, and curve data of their adjoining boundaries. If the existing right(s)-of-way is contained within the boundaries of the subdivision, then the area of the portion of the right(s)-of-way within the subdivision shall be shown;
- (xiv) all rights-of-way for streets, alleys, avenues, roads, and highways that will be created by the filing of the plat; their names, widths, bearings, distances, curve data, and area;
- (xv) except as provided in (2)(e)(xiii) and (xiv), the location, bearings, distances, curve data, and areas of all parks, common areas, and other grounds dedicated for public use;
- (xvi) the total area of the subdivision;
- (xvii) a narrative legal description of the subdivision.
  - (a) The land surveyor, at his or her discretion, may choose the form of the narrative legal description as follows:
    - (I) If the land to be subdivided is either an aliquot part of a U.S. government section or a U.S. government lot, the narrative legal description may be the aliquot part or the government lot description of the land;
    - (II) If the plat depicts the division of one or more parcels shown on a previously filed certificate of survey or plat, the narrative legal description may be the number of the previously filed certificate of survey or name of the previously filed plat and the parcel number of the parcel(s) previously surveyed;
    - (III) The narrative legal description may be the metes-and-bounds description of the perimeter boundary of the subdivision; or
    - (IV) If the narrative legal description does not fall within (2)(e)(xvii)(A)(I) or (II), the narrative legal description required by this subsection is the metes-and-bounds description of the perimeter boundary of the subdivision.
  - (b) When the narrative legal description is metes-and-bounds, the point of beginning, which is also the point of closure of the legal description of the subdivision surveyed, must be labeled "Point of Beginning." Alternatively, the point of beginning may be labeled "POB" if the abbreviation is defined on the plat.
- (xviii) the dated signature and the seal of the land surveyor responsible for the survey. The land surveyor's signature certifies that the plat has been prepared in conformance with the applicable sections of the Montana Subdivision and Platting Act and the regulations

adopted under the Act. The land surveyor's signature and certification do not include certification of the Conditions of Approval sheet(s);

(xix) a memorandum of any oaths administered under 76-3-405, MCA;

(xx) the dated, signed, and acknowledged consent to the subdivision of the owner of the land to be subdivided. For purposes of this rule, when the parcel of land proposed for subdivision is being conveyed under a contract-for-deed, the terms "property owner," "landowner," and "owner" mean the seller of the land under the contract-for-deed;

(xxi) certification by the governing body that the final plat is approved;

(xxii) if applicable, the landowner's certificate of dedication of streets, alleys, avenues, roads, highways, parks, playground easements, or other public improvements;

(xxiii) if applicable, or as required by subdivision regulations, the landowner(s)' certification statement(s) as follows:

(a) A statement that federal, state, and local plans, policies, regulations, and/or conditions of subdivision approval that may limit the use of the property, including the location, size, and use are shown on the Conditions of Approval sheet or as otherwise stated.

(b) A statement that buyers of property should ensure that they have obtained and reviewed all sheets of the plat and all documents recorded and filed in conjunction with the plat and that buyers of property are strongly encouraged to contact the local planning department and become informed of any limitations on the use of the property prior to closing.

(c) A statement that all or part of the required public improvements have been installed and/or security requirements pursuant to 76-3-507, MCA, secure the future construction of any remaining public improvements to be installed.

(xxiv) if applicable, a certificate of the governing body accepting any dedicated land, easements, or improvements;

(xxv) if applicable, the certificate of the examining land surveyor;

(xxvi) space for the clerk and recorder's filing information; and

(xxvii) a minimum two-inch by four-inch blank space below the clerk and recorder's filing information for the recording numbers of the documents listed in (5).

(f) The land surveyor, at his or her discretion, may provide additional information on the plat regarding the survey.

(3) The following certifications of final plat approval must appear on the plat or on the Conditions of Approval sheet as contained in (4), or recorded or filed as contained in (5) of these rules:

(a) A certification by the county treasurer that all real property taxes and special assessments assessed and levied on the land to be subdivided have been paid and, if applicable, certification of the local health officer having jurisdiction.

(4) If applicable, a sheet(s) of the plat prepared by the landowner(s) or their representative(s) depicting conformance with subdivision application approval shall be entitled "Conditions of Approval of [insert name of subdivision]" with a title block including the quarter-section, section, township, range, principal meridian, county, and, if applicable, city or town in which the subdivision is located, and shall contain:

(a) any text and/or graphic representations of requirements by the governing body for final plat approval including, but not limited to, setbacks from streams or riparian areas, floodplain boundaries, no-build areas, building envelopes, or the use of particular parcels;

- (b) a certification statement by the landowner that the text and/or graphics shown on the Conditions of Approval sheet(s) represent(s) requirements by the governing body for final plat approval and that all conditions of subdivision application have been satisfied; and
  - (c) a notation stating that the information shown is current as of the date of the certification required in (4)(b), and that changes to any land-use restrictions or encumbrances may be made by amendments to covenants, zoning regulations, easements, or other documents as allowed by law or by local regulations.
- (5) If applicable, the following documents as specified by local government shall accompany the approved final plat and shall be recorded or filed with the plat as specified by the clerk and recorder, and the recording or filing number(s) for each document may be written on the plat by the clerk and recorder:
- (a) a title report or certificate of a title abstractor showing the names of the owners of record of the land to be subdivided, and the names of any lien holders or claimants of record against the land, and the written consent to the subdivision by the owners of the land if other than the subdivider, and any lien holders or claimants of record against the land;
  - (b) any covenants or deed restrictions relating to the subdivision;
  - (c) for lots less than 20 acres in size, exclusive of public roadways, a certification from the Montana Department of Environmental Quality stating that it has approved the plans and specifications for water supply and sanitary facilities pursuant to 76-4-104(2), MCA;
  - (d) if required by the governing body, for lots of 20 acres or greater in size, written documentation that the subdivider has demonstrated that there is an adequate water source and at least one area for a septic system and replacement drainfield for each lot in accordance with 76-3-604(8)(b), MCA;
  - (e) a copy of any security requirements, pursuant to 76-3-507, MCA, securing the future construction of any remaining public improvements to be installed;
  - (f) unless otherwise provided in local subdivision regulations, copies of final plans, profiles, grades, and specifications for improvements, including a complete grading and drainage plan, with the certification of a professional engineer that all required improvements which have been installed are in conformance with the attached plans. Local subdivision regulations may authorize the subdivider, under conditions satisfactory to the governing body, to prepare these plans and specifications after the final plat has been filed, or file them with a government official other than the clerk and recorder, or both. If the approved plans and specifications are or will be filed with a government official other than the clerk and recorder, then a document or a statement on the Conditions of Approval sheet that states where the plans can be obtained must be filed or recorded;
  - (g) if a street, alley, avenue, road, or highway created by the plat will intersect with a state or federal right-of-way, a copy of the access or encroachment permit; and
  - (h) any other documents satisfying subdivision application approval required by the governing body to be filed or recorded.

## APPENDIX 2: POTENTIAL AGENCY CONTACTS

---

Pursuant to Section 76-3-504(1)(q)(iii), MCA, a subdivider shall be provided a list of public utilities, those agencies of local, state, and federal government, and any other entities that may be contacted for comment on the subdivision application and the timeframe that the public utilities, agencies, and other entities are given to respond. Please provide agencies with a minimum of 30 days to respond or provide comment on subdivision applications. This list may not include all departments or agencies for a specific project location.

### ***Federal:***

- Fish, Wildlife, and Parks Service
- Bureau of Reclamation
- Geological Survey (USGS)
- Federal Emergency Management Agency (FEMA)
- Bureau of Land Management (BLM)
- Natural Resources Conservation Services (NRCS)

### ***State of Montana:***

- Department of Transportation (MDT)
- Department of Fish, Wildlife, and Parks Service (MT FWPS)
- Department of Environmental Quality (MT DEQ)
- Department of Natural Resources and Conservation (MDNRC)
- Bureau of Mines and Geology
- Montana State Historic Preservation Office (MT SHPO)

### ***Madison County:***

- Sanitarian Office
- Road Department
- Sheriff
- Solid Waste
- Weed Board/District
- Superintendent of Schools
- Fire Warden/Office of Emergency Management
- Conservation District
- Planning Department and Floodplain Administrator

### ***Other:***

- Postal Services
- Utility Providers
- Airport Authority
- Railway Systems
- Ambulance Services & Medical Service Providers
- Fire Departments/District
- Irrigation District
- Water and Sewer Districts
- Adjacent Subdivision Homeowners Associations
- Town Officials and/or Planning Board
- Other pertinent agencies or subcontractors

## APPENDIX 3: ENVIRONMENTAL PERMITS

Permit	Contacts	Description
<b>Airport Affected Area</b>	Madison County Planning Office Madison County Airport Board	Need a permit if use changes or new development within AAA.
<b>Building Codes</b>	Department of Labor and Industry Business standards Division	Need permit for all construction <b>other than</b> residential structures with fewer than five units, ag buildings, private garages and storage, etc
<b>County Road Permits</b>	Madison County Board of County Commission	Need permit for approach/encroachments.
<b>Floodplain</b>	County Floodplain Administrator	Need permit for uses in designated floodplain.
<b>Heritage Sites Antiquities Permit</b>	Montana Historical Society-State Historic Preservation Office	Need permit to excavate, remove, or restore a heritage property.
<b>Highway Approach</b>	MT Department of Transportation	Need permit for construction of driveways and other approaches intersecting highways and streets.
<b>Highway Encroachment</b>	MT Department of Transportation	Need permit for construction or maintenance of encroachments on or under highway right-of-way
<b>Improvement Districts</b>	Madison County Board of County Commissioners	Contact local government authorities for more specific information.
<b>Public Sewer System</b>	Department of Environmental Quality	DEQ regulates systems serving 15 connections or more, used by at least 25 persons, for 60 days or more.
<b>Public Water Supply</b>	Department of Environmental Quality	DEQ regulates systems serving 15 connections or more, used by at least 25 persons, for 60 days or more.
<b>River Setbacks/ Other Regulations</b>	Madison County Planning Office	Setback on all construction on the Big Hole River. Setbacks applicable to subdivisions on other rivers and streams in the county.
<b>Sanitation in Subdivisions</b>	Department of Environmental Quality County Sanitarian	Need permit for water and septic systems. Lots smaller than 20 acres are reviewed by DEQ. Larger lots are reviewed by the county.
<b>Stream Beds Stream Banks</b>	Local Conservation District, DNRC	Need 310 permit for engineering operations for dams, dikes, ponds, ditches, fences, stream crossings, bank stabilization, irrigation diversions, headgates, pumpsite maintenance, etc
<b>Subdivision and Platting Act</b>	Madison County Planning Office	Subdivision regulations apply to all divisions of land less than 160 acres in size, condominiums, mobile home parks and RV parks.
<b>Utility Lines</b>	Local Municipalities or County Commission	Utility lines construction may be regulated by the county or local municipality in certain areas.
<b>Water Appropriations</b>	Department of Natural Resources & Conservation	Need permit for a well that exceeds 35 gallons per minute or 10 acre-feet of water per year. Also, for state water surface diversions.

<b>Permit</b>	<b>Contacts</b>	<b>Description</b>
<b>Water Quality</b>	Department of Environmental Quality	Permit needed to construct, modify, or operate a disposal system or to construct or use any outlet for discharge of sewage, industrial, or other wastes into state waters.
<b>Water Wells</b>	Montana DNRC MT Bureau of Mines & Geology	Water rights, exempt wells, well log reports.
<b>Wetlands</b>	U.S. Army Corps of Engineers	Permit is required for placement of dredged or mill materials in waters. Building near wetlands sites.
<b>Zoning</b>	Municipalities	Check with municipalities.

References: Montana Index of Environmental Permits: Montana Environmental Quality Council, 2014.  
Madison County Subdivision Regulations.

# APPENDIX 4: SUBDIVISION REVIEW PROCESS

---

## Typical Subdivision Application and Review Process for Subdivision

---

- Minor Subdivisions consist of five or fewer lots
  - Major Subdivisions consist of six or more lots
  - Administrative Minor Subdivisions follow the process outlined in Section III-C
- 

### **STEP ONE:** Pre-Application meeting with Planner/Subdivision Administrator

- Planner reviews the project proposal.
- Fees paid.

### **STEP TWO:** Preliminary Plat Application Submittal and Review

- Submit one copy of the subdivision preliminary plat application packet, plus application review fees, to Planner/Subdivision Administrator for element sufficiency review.

### **STEP THREE:** Additional Packets Submitted

- Once subdivision application packet has passed the element and sufficiency reviews, 20 additional packets/applications must be submitted by a date specified by the Planner/Subdivision Administrator.
- Thirty-five (35), sixty (60) or eighty (80) working day review “clock” begins day after written notice of sufficiency review completeness.

### **STEP FOUR:** Public Notification

- Public meeting or public hearing scheduled with the Planning Board and/or Commission.
- Planner/Subdivision Administrator issues legal notices and affected landowner notifications.
- Subdivider posts notifications on-site at project location.

### **STEP FIVE:** Planning Board Review

- Planning Board reviews subdivision preliminary plat application and holds a public meeting or public hearing.
- Planning Board makes a recommendation for approval, conditional approval, or denial to the Commission.

### **STEP SIX:** Governing Body Decision

- Governing body (Commission) reviews subdivision preliminary plat application and makes the decision to approve, conditionally approve, or deny the application at a public meeting or public hearing.

### **STEP SEVEN:** Final Plat Submittal

- Assuming approval or conditional approval of the preliminary plat, submit final plat application package (including final plat review fee) to Planner/Subdivision Administrator for review.
- Materials must be submitted prior to the expiration of the preliminary plat approval period.

### **STEP EIGHT:** Final Plat Approval

- Governing Body reviews the final plat and makes decision at public meeting.
- If final plat is approved, final plat is recorded.

# APPENDIX 5: REQUEST FOR PRE-APPLICATION

---

## Applicant Information

Date: \_\_\_\_\_ Fee Paid: \_\_\_\_\_

Type of Subdivision:     \_\_\_ First Minor     \_\_\_ Subsequent Minor     \_\_\_ Major  
                                  \_\_\_ Administrative Minor     \_\_\_ Amended Plat

Proposed Name of Subdivision: \_\_\_\_\_

Name of Landowner: \_\_\_\_\_  
Phone: \_\_\_\_\_ Email: \_\_\_\_\_  
Address: \_\_\_\_\_

Name of Subdivider/Developer/Applicant: \_\_\_\_\_  
Phone: \_\_\_\_\_ Email: \_\_\_\_\_  
Address: \_\_\_\_\_

Surveyor/Engineer: \_\_\_\_\_  
Phone: \_\_\_\_\_ Email: \_\_\_\_\_  
Address: \_\_\_\_\_

## Parcel Description

Legal Description: \_\_\_\_\_ of Section \_\_\_\_\_ Township \_\_\_\_\_ Range \_\_\_\_\_

Total Acreage: \_\_\_\_\_ Number of Lots: \_\_\_\_\_

Sanitation:     \_\_\_ County Sanitarian     \_\_\_ DEQ

Water and Sewer District:     \_\_\_ Yes     \_\_\_ No     Name: \_\_\_\_\_

Floodplain:     \_\_\_ Yes     \_\_\_ No     FIRM Panel Number: \_\_\_\_\_

Road Access (Names): \_\_\_\_\_

Existing Zoning:     \_\_\_ Yes     \_\_\_ No     Proposed Zoning:     \_\_\_ Yes     \_\_\_ No

Existing Land Use: \_\_\_\_\_

Proposed Land Use: \_\_\_\_\_

Type of Development:     \_\_\_ Single-Family Residential     \_\_\_ Multi-Family Residential  
                                  \_\_\_ Condominium     \_\_\_ Commercial/Industrial  
                                  \_\_\_ RV Park/Campground     \_\_\_ Other (describe)

Jurisdictional Area:     \_\_\_ Twin Bridges     \_\_\_ Sheridan     \_\_\_ Virginia City  
                                  \_\_\_ Ennis     \_\_\_ Unincorporated Madison County

## Attachments

### 1. Existing Conditions Sketch Map

The sketch may be a freehand sketch drawn directly on a print of a topographic map of the area proposed for subdivision at a scale of 1 inch to 400 feet or larger that is adequate to show the property and must include the following:

- location
- approximate tract and lot boundaries of existing tracts of record
- description of general terrain
- natural features on the land, including water bodies, floodplains, geologic hazards, and soil types
- existing structures and improvements
- existing utility lines and facilities serving the area to be subdivided
- existing easements and rights of way

### 2. Proposed Improvements Sketch Map

The sketch may be a freehand sketch drawn directly on a print of a topographic map of the area proposed for subdivision at a scale of 1 inch to 400 feet or larger that is adequate to show the property and must include the following:

- tract and proposed lot boundaries
- proposed public and private improvements
- location of utility lines and facilities
- easements and rights of way
- parks and open space and proposed conservation easements

### 3. Documentation on the current status of the site, including:

- ownership information, such as a deed, option to buy or buy-sell agreement, including permission to subdivide
- water rights, including location of agricultural water user facilities
- any special improvements districts
- rights of first refusal for the property
- existing zoning or development regulation standards
- existing conservation easements
- existing covenants or deed restrictions

### 4. Narrative description of the project/development.

*This form serves as a record of a pre-application meeting between the applicant and Madison County Planning Department. The applicant is hereby notified that this completed form, as well as any pre-application meeting discussion, does not guarantee Madison County's approval or conditional approval of the applicant's proposed subdivision.*

---

Applicant's Signature

---

Date

# APPENDIX 6: MODEL NOTIFICATION LETTER

---

NOTE: After subdivision application is submitted and determined to be sufficient.

---

**[Date Mailed]**

TO: Adjacent Property Owners  
Lien Holders  
Easement Holders  
Potentially Affected Water Users  
Potentially Affected Property Owner Associations  
Review Agencies  
Nearby Municipality

FROM: **[Landowner name and contact information. Also, name and contact information for landowner's representative, if pertinent]**

RE: **[Proposed Subdivision and Legal Description of Site]**

This is to notify you that the proposed **[name of subdivision]** has been submitted to Madison County and will be reviewed by the Madison County Planning Board as follows:

- **[day and date of meeting]**

---

- **[approximate meeting time]**

---

- **[meeting location]**

---

The subdivision application may be reviewed at the Planning Office or **[\_\_\_\_\_]**. A vicinity map and project summary are enclosed.

Your comments to the Planning Board about the project are welcomed, either prior to or at the meeting. If you wish to write or call in your comments, please address them to: Madison County Planning Board, P.O. Box 278, Virginia City, MT 59755; phone (406) 843-5250, fax (406) 843-5229. Email address: [planning@madisoncounty.mt.gov](mailto:planning@madisoncounty.mt.gov)

Enclosures

cc: Madison County Planning Board

# APPENDIX 7: PRELIMINARY PLAT APPLICATION CHECKLIST

## Section A: Completed by Subdivider

Name of Proposed Subdivision:

Location:

Property Owner:

Legal Description:

Property Geocode/Parcel ID:

Subdivider Comments:

**20 copies submitted to Planning Office (AFTER sufficiency is met):**

Preliminary Plat Application and Supplements, including 11'x17' draft of Preliminary Plat

One (1) 24"x36" copy of the Preliminary Plat

One (1) Preliminary Plat Application and supplements placed in local library, fire department, or town hall: Date \_\_\_\_\_ Location \_\_\_\_\_

## Section B: Completed by Planner/Subdivision Administrator

PLANNER REVIEW	Date:	By:	Comment:
Received:			
Element Review			
Element Complete:			
Sufficiency Review:			
Sufficiency Complete:			

**Section C: Completed by Subdivider and Planner/Subdivision Administrator**

Items and Information, Filled Out by: (Note if Not Applicable)	Subdivider	Planner/Subdivision Administrator			
		Element Review		Sufficiency Review	
		Missing	OK/NA	Missing	OK/NA
Documentation of Type of Subdivision					
Subdivision Assessment Form (Appendix 8)					
Subdivision Review Fees					
<b><i>Preliminary Plat Contents</i></b>					
Name and location of subdivision (Name should not duplicate another subdivision).					
Scale.					
North arrow.					
Date of preparation.					
Vicinity map.					
Approximate exterior boundaries of the platted tract and location of all section corners or legal subdivision corners of sections pertinent to the subdivision boundary.					
All lots and blocks, designated by numbers, and the approximate dimensions and area of each lot.					
All roadways and right-of-way width/grades/curvature of each, with existing and proposed roadway names (new road names have been approved by Madison County).					
Proposed intersection locations or other access points for any subdivision requiring access to highways, arterials, and collectors.					
Approximate location, boundaries, dimensions, and areas of all parks, common grounds, or other grounds dedicated for public use.					

Items and Information, Filled Out by: (Note if Not Applicable)	Subdivider	Planner/Subdivision Administrator			
		Element Review		Sufficiency Review	
		Missing	OK/NA	Missing	OK/NA
Existing and proposed utilities located on or adjacent to the tract, including: <ul style="list-style-type: none"> <li>• Approximate location, size, and depth of sanitary and storm sewers, water mains, fire hydrants, dry hydrants, and cisterns</li> <li>• Approximate location of gas, electric, and telephone lines, and street lights</li> <li>• Approximate location of the nearest water mains and sewer lines where none are located on or adjacent to the tract</li> <li>• Existing irrigation ditches and canals</li> </ul>					
Ground Elevations on the Tract. Contour intervals are provided at suggested vertical intervals of: two (2) feet where the average slope is 0-2%, five (5) feet where the average slope is 3-7%, and ten (10) feet where the average slope is over 7%. <i>Notes: (1) A cross section may be required to define drainage patterns. (2) United States Geological Survey data or other information may be used, if it presents an accurate and usable representation of ground features.</i>					
Approximate location of existing buildings, structures, and improvements.					
Approximate location and identity of existing and proposed public and private easements and rights-of-way, including description of their width and purpose. This includes conservation easements.					
Approximate location of any watercourses, including springs and surface water features.					
Floodplain-related delineations, where applicable.					

Items and Information, Filled Out by: (Note if Not Applicable)	Subdivider	Planner/Subdivision Administrator			
		Element Review		Sufficiency Review	
		Missing	OK/NA	Missing	OK/NA
Construction setbacks from any watercourse running through or immediately adjacent to the proposed subdivision.					
Names of adjoining platted subdivisions and numbers of adjoining COS's previously recorded.					
Ownership of all lands adjacent to the subdivision and to the access road leading from a present public right-of-way to the boundary of the proposed subdivision.					
<b><i>Preliminary Plat Supplements:</i></b>					
<p>A vicinity sketch or sketches showing conditions on subject land and adjacent land, including:</p> <ul style="list-style-type: none"> <li>• Ownership of lands immediately adjoining the subdivision.</li> <li>• Clear indication of the proposed subdivision on an U.S. Geological Survey topographic map, aerial photograph, and location map.</li> <li>• Approximate direction and gradient of ground slope, including any embankments or retaining walls, shown in contours of 2' where the average slope is less than 10% and 5' intervals where the average slope is greater than 10% but less than 15%, and intervals of 10' where the average slope is greater than 15%; slopes greater than 25% shall be shown as no-build zones.</li> <li>• Current land uses.</li> <li>• Location of existing structures, railroads, power lines, towers, roads, and other utilities.</li> <li>• Location of any known potential man-made or natural hazards.</li> </ul>					

Items and Information, Filled Out by: (Note if Not Applicable)	Subdivider	Planner/Subdivision Administrator			
		Element Review		Sufficiency Review	
		Missing	OK/NA	Missing	OK/NA
Any existing or proposed zoning (or other land use regulation) on the proposed subdivision tract and in the vicinity.					
A copy of the most current Certificate of Survey or subdivision plat pertaining to the subject parcel to be subdivided.					
Lienholder's acknowledgement of the proposed subdivision.					
Subdivision guarantee dated no more than six months prior to the date of Preliminary Plat submittal.					
Documentation of any existing covenants or deed restrictions.					
Drafts of any covenants and restrictions to be included in deeds or contracts for sale.					
Documentation of any existing easements, including those for Agricultural Water User Facilities.					
Proposed easements, including the location of nearest utilities.					
Documentation of legal and physical access.					
Documentation of approach, access, or encroachments permits submitted to the appropriate jurisdiction/authority.					
Proposed road plans and profiles, including the location and dimensions of the roads, developed by a PE.					
Transportation impact analysis or traffic study developed by a PE (if identified during the pre-application meeting).					
Existing water rights and proposed disposition of water rights.					

Items and Information, Filled Out by: (Note if Not Applicable)	Subdivider	Planner/Subdivision Administrator			
		Element Review		Sufficiency Review	
		Missing	OK/NA	Missing	OK/NA
A description of the proposed water supply systems, stormwater systems, solid waste disposal systems, and wastewater treatment systems, including: <ul style="list-style-type: none"> <li>• Whether the water supply and wastewater treatment systems are individual, shared, multi-user, or public</li> <li>• If the water supply and wastewater treatment systems are shared, multi-user, or public, a statement of whether the systems will be public utilities as defined in MCA 69-3-101 and subject to the jurisdiction of the public service commission or exempt (with an explanation of the exemption)</li> </ul>					
A copy of the full Montana DEQ application, including all design specifications.					
Stormwater Drainage Plan developed by a PE, compliant with DEQ Circular 8 and ARM 17.36.310, and other applicable water/wastewater information.					
If applicable, will-serve letter from a municipal water and sewer service or by a County water and/or sewer district created under MCA 7-13-2203 that supplies both water and sewer services.					
Narrative identifying the floodplain status of the subject property and analysis and identification of the Base Flood Elevation (BFE) on the property, developed by a PE (if applicable and identified during the pre-application meeting).					
Existing mineral rights and proposed disposition of mineral rights.					
If development is planned in phases, a phasing plan meeting the requirements of MCA 76-3-617.					

Items and Information, Filled Out by: (Note if Not Applicable)	Subdivider	Planner/Subdivision Administrator			
		Element Review		Sufficiency Review	
		Missing	OK/NA	Missing	OK/NA
Parkland dedication calculations, location of and description of proposed parkland, or proposal for cash-in-lieu.					
Environmental Assessment for major subdivisions.					
Summary of probable impacts for minor and major subdivisions (Section 76-3- 603(1)(a)(ii) and (b), MCA).					
Geotechnical Analysis/Report					
Noxious Weed Management Plan					
Fire Protection Plan					
Land Stewardship Plan					
Letter requesting a revocation of agricultural covenants.					
Letter indicating locations of cultural or historic resources.					
Letter identifying and proposing mitigation for potential hazards or other adverse impacts as identified in the pre-application meeting and not covered by any of the above required materials.					
Variance request, if applicable.					
Names and addresses of all lien holders, easement holders, potentially affected water users (if any, and if known), purchasers under contract for deed, and any property owners association potentially affected by the project, as determined by the planner.					
Names and addresses of public agencies and municipalities located within two (2) miles of the proposed subdivision (including any agencies who manage a road that would provide access to the development), and documentation that they have received at least 30 days' advanced notification of the proposed subdivision. Include any comments received.					

Items and Information, Filled Out by: (Note if Not Applicable)	Subdivider	Planner/Subdivision Administrator			
		Element Review		Sufficiency Review	
		Missing	OK/NA	Missing	OK/NA
If proposing a Minor subdivision, a copy of each instrument of transfer or tract pertaining to the subject property filed or recorded since October 1, 2003 (deeds, certificate of survey or subdivision plat, for example).					
Public and agency comments received.					
Special information for: <ul style="list-style-type: none"> <li>• Mobile home parks</li> <li>• Recreational vehicle parks</li> <li>• Condominiums or townhouses</li> </ul>					
Preliminary Plat Checklist (one copy only).					
Additional relevant and reasonable information, as identified by the Planner/Subdivision Administrator, that is pertinent to the required elements of the MSPA.					

## APPENDIX 8: SUBDIVISION ASSESSMENT FORM

---

Each subdivision application will be reviewed for compliance with the Guiding Principles, Goals and Objectives of the Madison County Growth Policy. Each project will also be reviewed for its potential effects on the Montana Subdivision and Platting Act Public Interest Review Criteria.

### **GUIDING PRINCIPLES, Madison County Growth Policy:**

- Preserve existing open space.
- Protect wildlife habitat.
- Preserve natural resources; specifically, water resources.
- Provide for affordable housing.
- Respect private property rights.
- Promote inclusivity of and connectivity between all communities within Madison County.
- New development should pay its own way.
- Respect our agricultural and rural community character.

### **GOALS and OBJECTIVES, Madison County Growth Policy:**

- *Housing.* Promote infill residential development within incorporated towns and provide opportunities for affordable housing.
- *Land Use.* Preserve existing open space and protect valuable agricultural land, plan for responsible, reasonable, and managed growth/development, protect the public health and safety of County residents, support zoning efforts, protect private property rights, and encourage municipal growth versus urban sprawl.
- *Environment.* Protect wildlife habitat, preserve natural resources and water resources, support growth in agriculture, forestry, recreation and tourism, and small service-based businesses in a manner that does not impact established residential communities, discourage development that will financially strain public services, and support infrastructure improvements within incorporated and unincorporated communities.
- *Communication, Coordination, and Citizen Participation.* Improve collaboration with incorporated towns and unincorporated communities, provide education and information on land use legislation and property rights, improve physical connectivity across the County, and collaborate with other local governments and agencies to provide better service to all Madison County residents.
- *Geographical Area-Specific Goals and Objectives.* Please reference the Growth Policy for specific goals and objectives for different geographical areas within Madison County.

**TEN PUBLIC INTEREST REVIEW CRITERIA:** Agriculture, agricultural water user facilities, natural environment, wildlife, wildlife habitat, local services, public health and safety, County resources, local economy, and public services provided by other entities in the County.

A proposed subdivision may have positive, neutral, and/or negative effects. Where potential negative effects are identified, the project may be required to include mitigation measures that will reduce or eliminate the negative impacts. In some cases, negative impacts cannot be mitigated and may be grounds for denial of the subdivision application.

***I've read and understand that the above criteria will be used in evaluating my subdivision application.***

\_\_\_\_\_

[Print Landowner Name Here]

\_\_\_\_\_

[Sign and Date Here]

# APPENDIX 9: VARIANCE APPLICATION FORM

---

1. **Project Name** \_\_\_\_\_

2. **Applicant Information**

Name: \_\_\_\_\_

Address: \_\_\_\_\_

Telephone: \_\_\_\_\_

Signature: \_\_\_\_\_ Date \_\_\_\_\_

3. **Describe the requested variance (with specific Section references) :** \_\_\_\_\_

\_\_\_\_\_

\_\_\_\_\_

4. **Describe how the requested variance meets each of the following criteria (Attach additional pages as needed):**

- a. The variance will not be detrimental to the public health, safety, or general welfare, or injurious to other adjoining properties.
- b. Because of the particular physical surroundings, shape, or topographical conditions of the specific property involved, an undue hardship to the owner would result if the strict letter of these regulations is enforced.
- c. The variance will not cause a substantial increase in public costs.
- d. The variance will not in any manner place the proposed subdivision in non-conformance with any adopted zoning regulations or in substantial non-compliance with the Madison County Growth Policy.

5. **As appropriate, discuss whether or not the variance is a part of an innovative development proposal which does not circumvent the purpose of the Madison County Subdivision Regulations.**

6. **Provide names and addresses of all adjoining property owners. Provide documentation that written notification of the variance request has been provided to them, plus any existing property owners association potentially affected by the project as determined by the planner.**

# APPENDIX 10: DECLARATION OF RIGHT TO FARM, DECLARATION OF EMERGENCY SERVICES INFORMATION

---

\_\_\_\_\_ of  
(Owner Names)

\_\_\_\_\_  
(Address)

“Owners” are the owners of the property situated in Madison County, Montana, more particularly described as: \_\_\_\_\_  
(Name of subdivision)

## RIGHT-TO-FARM

Owners hereby declare that this property shall be held, sold, and conveyed subject to the following acknowledgments, waivers, restrictions, and conditions:

**This property is situated in an agricultural area and may be subject to conditions resulting from commercial agricultural operations on adjacent land. Such operations may include: cultivation, harvesting, and storage of crops; livestock raising; application of chemicals; operation of machinery; application of irrigation water; and other accepted and customary agricultural activities conducted in accordance with federal and state law.**

**Such activities ordinarily and necessarily produce noise, dust, smoke, odor, and other conditions that may conflict with residential purposes. Grantees shall have no common law rights to object to normal and necessary agricultural management activities legally conducted on adjacent land which may conflict with use of the property for residential purposes. Grantees are specifically subject to 27-30-101, MCA.**

**Adjacent property owners shall have no ingress or egress upon or across this property by virtue of this Declaration, and nothing herein shall prohibit or otherwise restrict the enforcement of statutes or regulations of governmental agencies for activities conducted on adjacent property.**

These acknowledgments, waivers, restrictions, and conditions shall run with the real property and shall be binding on all parties having or acquiring any right, title, or interest in the described property or any part thereof, and shall inure to the benefit of and be binding upon each successor in interest of the owners thereof.

# APPENDIX 11: LAND STEWARDSHIP PLAN

---

Submittal of a land stewardship plan is a requirement of the subdivision application package. The Land Stewardship Plan is intended to demonstrate that the subdivider has considered and, to the extent possible, provided for the long-term care and management of the land. The plan does not have to be lengthy, but it should address at least the major points listed below. Resource management plans prepared by ranches for other purposes may contain all or most of the pertinent considerations.

- **Vegetative Health**

*Where a subdivision is proposed in or near the Wildland-Urban interface, address the measures to be taken to address Wildland Fuel Mitigation with the intent to reduce fuel loading and provide for continuous maintenance of the fuel load.*

*In part, this item will be covered by the noxious weed management plan.*

*In part, this item will also be covered by best management practices for grazing and other agricultural uses (see below).*

*In addition, revegetation of disturbed ground and other landscaping requirements may be required or advisable. In such cases, native seed and plantings are encouraged.*

Suggested contacts: County Extension Agent, County Weed Coordinator, County Fire Warden, Natural Resource Conservation Service, Local Conservation District, and Local Fire District.

- **Public Access**

*Where a proposed subdivision will permit public access to recreational resources, what measures will be taken to minimize the potential for trespass, litter, and environmental damage?*

Suggested contacts: US Forest Service Regional Office, MT Department of Fish, Wildlife and Parks, County Attorney, and County Sheriff.

- **Wildlife**

*Where a subdivision is proposed in an area rich in wildlife resources, what measures will be taken to avoid habituating the wildlife, harassing the wildlife, obstructing wildlife migration patterns, unnecessarily attracting dangerous wildlife, and/or causing game damage on adjoining properties? Remember that building and road location, fencing options, garbage containment, pets, landscaping choices, hunting policies, etc. may all impact wildlife.*

Suggested contacts: MT Department of Fish, Wildlife and Parks, County Extension Agent, Natural Resource Conservation Service, Local Conservation District.

- **Livestock Grazing**

*Where a proposed subdivision will allow livestock grazing (including horses), what measures will be taken to prevent overgrazing, provide adequate forage, and promote healthy vegetation? Where a proposed subdivision will prohibit livestock grazing on large tracts of land, how will the land be managed to prevent wildfire and noxious weeds and promote healthy vegetation?*

Suggested contacts: Natural Resource Conservation Service, Local Conservation District, County Extension Agent, and County Weed Coordinator.

- **Other Agricultural Uses**

*Where a proposed subdivision will allow other agricultural uses, what measures will be taken to promote soil health and water conservation?*

Suggested contacts: Natural Resource Conservation Service, Local Conservation District, County Extension Agent.

- **Solid Waste and/or Recycling**

*What solid waste and recycling practices will be promoted, and how?*

Suggested contact: County Sanitarian or Solid Waste Manager

- **Protection of Water Resources**

*Where a proposed subdivision is located along a stream or lake, what measures will be taken to protect surface water, groundwater, floodplain, and riparian area resources?*

*In part, this item will be covered by sanitation and floodplain information.*

*In part, this item will also be covered by previous discussions of wildlife, livestock grazing, and other agricultural uses.*

Suggested contacts: County Floodplain Administrator, Local Conservation District or Watershed Council, County Extension Agent, and US Army Corps of Engineers.

# APPENDIX 12: ENVIRONMENTAL ASSESSMENT

---

Information specified in this part must be provided in addition to that required in Appendices 13 and 14 of this document, unless the proposed subdivision qualifies for an exemption under Chapter IX of these subdivision regulations. For specific hydrogeological requirements, please refer to the Madison County Environmental Assessment Policy.

Describe the following environmental features, provide responses to each of the following questions (each question must precede its response) and provide reference materials, as required. All materials and reports submitted for major subdivisions must be submitted in the following order: **Environmental Assessment (Appendix 12), Summary of Probable Impacts (Appendix 13), and Community Impact Report (Appendix 14)**. Subdivisions processed as minor subdivisions according to Chapter III of these regulations must only submit a Summary of Probable Impacts (Appendix 13).

All materials and reports should be clearly typed, any handwritten materials or reports must be clearly legible. Responses should cite any reference materials that apply to a topic or selection. If the proposed development will not have an impact on a particular topic or selection the subdivider must provide information and a detailed analysis as to why there will be no impact.

## 1) Surface Water

- a) Locate on a plat overlay or sketch map:
  - i) Any natural water systems such as streams, rivers, intermittent marshes (also include the names and sizes of each).
  - ii) Any artificial water systems such as canals, ditches, aqueducts, reservoirs, and irrigation systems (also include the names, sizes, and present uses of each).
  - iii) Time when water is present (seasonally or all year).
  - iv) Any areas subject to flood hazard, or in delineated 100-year floodplain.
  - v) Describe any existing or proposed stream bank alteration from any proposed construction or modification of lake beds or stream channels. Provide information on location, extent, type, and purpose of alteration, and permits applied for.

## 2) Groundwater

- a) Using available data, provide the following information:
  - i) The minimum depth to water table and identify dates when depths were determined. What is the location and depth of all aquifers which may be affected by the proposed subdivision? Describe the location of known aquifer recharge areas which may be affected.
  - ii) Describe any steps necessary to avoid depletion or degradation of groundwater recharge areas.

## 3) Topography, Geology, and Soils

- a) Provide a map of the topography of the area to be subdivided, and an evaluation of suitability for the proposed land uses. On the map identify any areas with highly erodible soils or slopes in excess of 15% grade. Identify the lots or areas affected. Address conditions such as:
  - i) Shallow bedrock
  - ii) Unstable slopes

- iii) Unstable or expansive soils
- iv) Excessive slope
- b) Locate on an overlay or sketch map:
  - i) Any known hazards affecting the development which could result in property damage or personal injury due to:
    - (1) Falls, slides, or slumps – soil, rock, mud, snow
    - (2) Rock outcroppings
    - (3) Seismic activity
    - (4) High water table
  - c) Describe measures proposed to prevent or reduce these dangers.
  - d) Describe the location and amount of any cut or fill more than three feet in depth. Indicate these cuts or fills on a plat overlay or sketch map. Where cuts or fills are necessary, describe plans to prevent erosion and to promote vegetation such as replacement of topsoil and grading.
  - e) In considering any unusual conditions, specifically address any problems which may be encountered during excavation for:
    - i) Basements
    - ii) Water supply trenches
    - iii) Sewer line trenches
    - iv) Septic tank and drain fields
    - v) Underground electrical and telephone lines

#### **4) Vegetation**

- a) On a plat overlay or sketch map:
  - i) Indicate the distribution of the major vegetation types, such as marsh, grassland, shrub, coniferous forest, deciduous forest, mixed forest, etc.
  - ii) Identify the location of critical plant communities such as:
    - (1) Stream bank or shoreline vegetation
    - (2) Vegetation on steep, unstable slopes
    - (3) Vegetation on soils highly susceptible to wind or water erosion
    - (4) Type and extent of noxious weeds
  - iii) Describe measures to:
    - (1) Preserve trees and other natural vegetation (e.g. locating roads and lot boundaries or planning construction to avoid damaging tree cover)
    - (2) Protect critical plant communities (e.g. keeping structural development away from these areas or designating open space areas)
    - (3) Prevent and control grass, brush, forest fuels, and forest fires (e.g. green strips, water supply, access)
    - (4) Control and prevent the growth of noxious weeds

#### **5) Wildlife**

- a) Identify species of fish and wildlife using the area that may be affected by the proposed subdivision.
- b) On a copy of the Preliminary Plat or overlay, identify known critical wildlife areas, such as big game winter range, calving areas and migration routes, riparian habitat and waterfowl nesting areas, habitat for rare or endangered species, and wetlands.

- c) Describe proposed measures to protect or enhance wildlife habitat or to minimize degradation (e.g. providing shoreline setbacks, designating open space or no-build areas to protect wetlands).

# APPENDIX 13: SUMMARY OF PROBABLE IMPACTS

---

Describe in detail the probable impacts of the proposed subdivision on each topic below. Provide responses to each of the following questions (each question must precede its response) and provide reference materials, as necessary or required.

All materials and reports submitted for major subdivisions must be submitted in the following order: **Environmental Assessment (Appendix 12), Summary of Probable Impacts (Appendix 13), and Community Impact Report (Appendix 14)**. Subdivisions processed as minor subdivisions according to Chapter III of these regulations must only submit a Summary of Probable Impacts (Appendix 12).

All materials and reports should be clearly typed, any handwritten materials or reports must be clearly legible. Responses should cite any reference materials that apply to a topic or selection. If the proposed development will not have an impact on a particular topic or selection the subdivider must provide information and a detailed analysis as to why there will be no impact.

## 1) Effects on Agriculture

- a) Is the proposed subdivision or associated improvement located on or near prime farmland or farmland of statewide importance, as defined by the Natural Resource Conservation Service? If so, identify each area on a copy of the preliminary plat.
- b) Describe whether the subdivision would remove from production any agricultural or timber land.
- c) Describe in detail the possible conflicts with nearby agricultural operations (e.g. residential development creating problems for moving livestock, operating farm machinery, maintaining water supplies, controlling weeds or applying pesticides, agricultural operation suffering from vandalism, uncontrolled pets or damaged fences).
- d) Describe in detail the possible nuisance problems which may arise from locating a subdivision near agricultural or timber lands.
- e) Describe in detail the effects the subdivision would have on the value of nearby agricultural lands.
  - i) Would the market, mortgage, and taxable value of the nearby agricultural land increase?
  - ii) Would the increased market value and the conditions in b, c, and d above encourage further land division or otherwise remove land from production?
- f) Would the costs of providing additional educational and other public facilities result in higher mill levies on agricultural properties?

## 2) Effects on Agricultural Water User Facilities

- a) Describe conflicts the subdivision would create with agricultural water user facilities (e.g. residential development creating problems for operating and maintaining irrigation systems) and whether agricultural water user facilities would be more subject to vandalism or damage because of the subdivision.
- b) Describe possible nuisance problems which the subdivision could potentially generate with regard to agricultural water user facilities (e.g. safety hazards to residents or water problems from irrigation ditches, head gates, siphons, sprinkler systems, or other agricultural water user facilities).

## 3) Effects on Local Services

- a) Indicate the proposed use and number of lots or spaces for each type of use (e.g. single-family residential, multi-family residential, types of multi-family structures and number of each, condominium, mobile home park, recreational vehicle park, commercial, industrial, other uses).
- b) Describe the additional or expanded public services and facilities that would be demanded of local government or special districts to serve the subdivision.
  - i) Describe additional costs for services such as roads, bridges, law enforcement, parks and recreation, fire protection, water, sewer, solid waste systems, schools or busing, including additional personnel, construction, and maintenance costs).
  - ii) Who would bear these costs (e.g. all taxpayers within the jurisdiction, people within special taxing districts, or user of a service)?
  - iii) Can the service providers meet the additional costs, given legal and other constraints (e.g. statutory ceilings on mill levies or bonded indebtedness)?
  - iv) Describe off-site costs or costs to other jurisdictions that may be incurred (e.g. development of water sources or construction of a sewage treatment plant, costs borne by a nearby municipality).
- c) Describe how the subdivision allows existing services, through expanded use, to operate more efficiently, or makes the installation or improvement of services feasible (e.g. allowing installation of a central water system or upgrading a County road).
- d) What are the present tax revenues received from the unsubdivided land?
  - i) By the County \$ \_\_\_\_\_
  - ii) By the municipality, if applicable \$ \_\_\_\_\_
  - iii) By the school(s) \$ \_\_\_\_\_
- e) Provide the approximate revenues received by each of the above taxing authority if the lots are reclassified, and when the lots are all improved and developed. Describe any other taxes that would be paid by the subdivision and into what funds (e.g. personal property taxes on mobile/manufactured homes are paid into the County general fund).
- f) Would new taxes generated from the subdivision cover additional public costs?
- g) How many special improvement districts would be created, which would obligate local government fiscally or administratively? Are any bonding plans proposed which would affect the local government's bonded indebtedness?

#### **4) Effects on the Historic or Natural Environment**

- a) Describe and locate on a plat overlay or sketch map known or possible historic, paleontological archaeological or cultural sites, structures, or objects which may be affected by the proposed subdivision.
- b) How would the subdivision affect surface and groundwater, soils, slopes, vegetation, historical or archaeological features within the subdivision or adjacent land? Describe plans to protect these sites.
  - i) Would any stream banks or lake shorelines be altered, streams re-channeled, or any surface water contaminated from sewage treatment systems, runoff carrying sedimentation, or concentration of pesticides or fertilizers?
  - ii) Would groundwater supplies likely be contaminated or depleted as a result of the subdivision?
  - iii) Would construction of roads or building sites require cuts and fills on steep slopes or cause erosion on unstable, erodible soils? Would soils be contaminated by sewage treatment systems?
  - iv) Describe the impacts that removal of vegetation would have on soil erosion, bank or shoreline instability.

- v) Would the value of significant historical, visual, or open space features be reduced or eliminated?
- vi) Describe possible natural hazards the subdivision could be subject to (e.g. flooding, rock slides, snow slides, landslides, high winds, wildfire risk, or difficulties such as shallow bedrock, high water table, unstable or expansive soils, or excessive slopes).
- c) How would the subdivision affect visual features within the subdivision or on adjacent land? Describe efforts to visually blend the proposed development with the existing environment (e.g. use of appropriate building materials, colors, road design, underground utilities, and re-vegetation of earthworks).

#### **5) Effects on Wildlife**

- a) Describe in detail what impacts the subdivision or associated improvements would have on wildlife in the area.
- b) Describe in detail the effect that pets or human activity would have on wildlife in the area.

#### **6) Effects on Wildlife Habitat**

- a) Describe in detail what impacts the subdivision or associated improvements would have on wildlife habitat areas such as big game wintering range, migration routes, nesting areas, wetlands, or important habitat for rare or endangered species.
- b) Describe in detail the effect that pets or human activity would have on wildlife habitat in the area.

#### **7) Effects on Public Health and Safety**

- a) Describe in detail any health or safety hazards on or near the subdivision, such as: natural hazards, lack of water, drainage problems, heavy traffic, dilapidated structures, high pressure gas lines, high voltage power lines, high hazard dams, or irrigation ditches. These conditions, proposed or existing, should be accurately described with their origin and location identified on a copy of the preliminary plat.
- b) Describe in detail how the subdivision would be subject to hazardous conditions due to high voltage lines, airports, highways, railroads, dilapidated structures, high pressure gas lines, high hazard dams, irrigation ditches, and adjacent industrial or mining uses.
- c) Describe in detail land uses adjacent to the subdivision and how the subdivision will affect these uses. Identify existing uses such as feed lots, processing plants, airports, or industrial firms that could be subject to complaints from residents of the subdivision.
- d) Describe in detail public health or safety hazards created by the subdivision, such as dangerous traffic, fire conditions, or contamination of water supplies.

#### **8) Compliance with Survey Requirements, Local Subdivision Regulations, and Review Procedures**

- a) Describe in detail compliance with survey requirements, local subdivision regulations, and review procedures. Provide responses to each of the following questions and provide reference materials, as applicable or required.
  - i) Does the subdivision meet the requirements of the Montana Subdivision and Platting Act, the surveying requirement specified in the Uniform Standards for Monumentation, and the Madison County Subdivision Regulations? Note any variances requested.
  - ii) Has the subdivision review procedure been followed?

**9) Provision of Easements for the Location and Installation of Any Planned Utilities**

- a) Describe in detail the provision of easements for the location and installation of any planned utilities. Provide responses to each of the following questions and provide reference materials, as applicable and required.
  - i) Indicate what utilities will be supplied.
  - ii) Indicate the utility provider(s) who will provide electrical power, natural gas, or telephone services. To what extent will these utilities be placed underground? What arrangement have been made to secure these utilities?
  - iii) Describe proposed street lighting and who will provide it?
  - iv) Has the preliminary plat been submitted to affected utilities and utility providers for review?
  - v) Estimate the completion date of each utility installation.
  - vi) Does the subdivision provide easements for the location and installation of utilities, as specified in these regulations?
  - vii) Are all easements, both proposed and existing, clearly noted and included on the face of the plat?

# APPENDIX 14: COMMUNITY IMPACT REPORT

---

Provide a community impact report containing a statement of estimated number of people coming into the area as a result of the subdivision, anticipated needs of the proposed subdivision for public facilities and services, and the increased capital and operating costs to each affected unit of local government. Provide responses to each of the following questions (each question must precede its response) and provide reference materials as required.

All materials and reports submitted for major subdivisions must be submitted in the following order: **Environmental Assessment (Appendix 12), Summary of Probable Impacts (Appendix 13), and Community Impacts Report (Appendix 14)**. Subdivisions processed as minor subdivisions according to Chapter III of these regulations must only submit a Summary of Probably Impacts (Appendix 13).

All materials and reports should be clearly typed, any handwritten material or reports must be clearly legible. Responses should cite any reference materials that apply to a topic or selection. If the proposed development will not have an impact on a particular topic or selection the subdivider must provide information and a detailed analysis as to why there will be no impact.

## 1. Education and Busing

- a. Describe the available educational facilities which would serve this subdivision.
- b. Estimate the number of school children that will be added by the proposed subdivision. Provide a statement from the administrator of the affected school system indicating whether the increased enrollment can be accommodated by the present personnel and facilities by the existing school bus system. If not, estimate the increased expenditures that would be necessary to do so.

## 2. Roads and Maintenance

- a. Estimate how much daily traffic the subdivision, when fully occupied, will generate on existing streets and arterials.
- b. Describe the capability of existing and proposed roads to safely accommodate this increased traffic.
- c. Describe increased maintenance problems and increased costs due to this increase in volume.
- d. Describe proposed new public or private access roads including:
  - i. Measures for disposing of storm run-off from streets and roads.
  - ii. Type of road surface and provisions to be made for dust.
  - iii. Facilities for streams or drainage crossings (e.g. culverts, bridges).
  - iv. Seeding of disturbed areas.
- e. Describe the closing or modification of any existing roads.
- f. Explain why road access was not provided within the subdivision, if access to any individual lot is directly from arterial streets or roads.
- g. Is year-round access by conventional automobile over legal rights-of-way available to the subdivision and to all lots and common facilities within the subdivision? Identify the owners of any private property over which access to the subdivision will be provided.

- h. Estimate the cost and completion date of the system, and indicate who will pay the cost of installation, maintenance, and snow removal.

### **3. Water, Sewage, and Solid Waste Facilities**

- a. Briefly describe the water supply and sewage treatment systems to be used in serving the proposed subdivision (e.g., methods, capacities, locations).
- b. Provide information on the estimated cost of the system, who will bear the costs, and how the system will be financed.
- c. Where hook-up to an existing system is proposed, describe estimated impacts on the existing system, and show evidence that permission has been granted to hook up to the existing system.
- d. All water supply and sewage treatment plans and specifications will be reviewed and approved by the Department of Environmental Quality (DEQ) and should be submitted using the appropriate DEQ application form.
- e. Describe the proposed method of collecting and disposing of solid waste from the development.
- f. If use of an existing collection system or disposal facility is proposed indicate the name and location of the facility.

### **4. Fire and Police Protection**

- a. Describe the fire and police protection services available to the residents of the proposed subdivision including number of personnel and number of vehicles or type of facilities for:
  - i. Fire protection -- Is the proposed subdivision in an existing fire district? If not, will one be formed or extended? Describe what fire protection procedures are planned?
  - ii. Law Enforcement -- Is the proposed subdivision within the jurisdiction of a County Sheriff or municipal police department.
- b. Can the fire and police protection service needs of the proposed subdivision be met by present personnel and facilities? If not, describe the additional expenses that would be necessary to make these services adequate, and who would pay the costs?

### **5. Payment for extension of Capital Facilities**

- a. Indicate how the subdivider will pay for the cost of extending capital facilities resulting from expected impacts directly attributable to the subdivision

# APPENDIX 15: EMERGENCY SERVICES INFORMATION

At the time of final plat filing, emergency service providers and their estimated response times under good weather conditions are:

AGENCY	RESPONSE TIME
Fire	
Ambulance	
Law Enforcement	

NOTE: In bad weather, access may be difficult or nonexistent.

In accordance with Madison County Ordinance 1-93, the road providing primary access to this subdivision is closed to vehicle traffic other than snowmobiles from December 1st of each year to April 15th of the following calendar year.

Applicable       Not Applicable

IN WITNESS WHEREOF, the landowner/developer has caused this instrument to be made and executed this \_\_\_\_ day of \_\_\_\_\_, 20 \_\_\_\_.

\_\_\_\_\_  
Landowner/Developer Name

\_\_\_\_\_  
Landowner/Developer Signature

STATE OF MONTANA  
County of Madison

On this \_\_\_\_ day of \_\_\_\_\_, 20 \_\_\_\_, before me personally appeared \_\_\_\_\_, known to me to be the persons whose names are subscribed to within this instrument and who acknowledge to me that they executed the same.

\_\_\_\_\_  
Notary Public for State of Montana  
Residing at \_\_\_\_\_  
My Commission Expires \_\_\_\_\_

# APPENDIX 16: REVIEWING FOR GROWTH POLICY COMPLIANCE

## EVALUATION CHECKLIST (for Proposed Subdivisions)

	Is the project consistent with the Growth Policy?						Comments
	As Proposed			With Additional Mitigation			
	Y	N	N/A	Y	N	N/A	
<b>GUIDING PRINCIPLES</b>							
#1. Preserve existing open space.							
#2. Protect wildlife habitat.							
#3. Preserve natural resources; specifically, water resources.							
#4. Provide for affordable housing.							
#5. Respect private property rights.							
#6. Promote inclusivity of and connectivity between all communities within Madison County.							
#7. New development should pay its own way.							
#8. Respect our agricultural and rural community character.							
<b>GOALS AND OBJECTIVES</b>							
<i>Housing.</i> Promote infill residential development within incorporated towns and provide opportunities for affordable housing.							
<i>Land Use.</i> Preserve existing open space and protect valuable agricultural land, plan for responsible, reasonable, and managed growth/development, protect the public health and safety of County residents, support zoning efforts, protect private property rights, and encourage municipal							

growth versus urban sprawl.							
<i>Environment.</i> Protect wildlife habitat, preserve natural resources and water resources, support growth in agriculture, forestry, recreation and tourism, and small service-based businesses in a manner that does not impact established residential communities, discourage development that will financially strain public services, and support infrastructure improvements within incorporated and unincorporated communities.							
<i>Communication, Coordination, and Citizen Participation.</i> Improve collaboration with incorporated towns and unincorporated communities, provide education and information on land use legislation and property rights, improve physical connectivity across the County, and collaborate with other local governments and agencies to provide better service to all Madison County residents.							
<i>Geographical Area-Specific Goals and Objectives.</i> Compliance with the goals and objectives identified for specific communities within designated geographical areas of Madison County.							
<b>COMPLIANCE WITH OTHER PLANS AND REGULATIONS</b>							
Community Wildfire Protection Plan							
Ordinance 1-2024 (Floodplain)							
Ordinance 30-2014 (Airport Affected Area)							
Other Community Plans							

Conclusions:

1. As proposed, the project DOES / DOES NOT substantially comply with the Madison County Growth Policy; **OR**
2. Additional mitigation measures ARE / ARE NOT needed to bring the project into substantial compliance with the Growth Policy.

Evaluated by \_\_\_\_\_ Date \_\_\_\_\_

# APPENDIX 17: PRELIMINARY PLAT EXTENSION FORM

<b>1. Project Information</b>
Project Name: _____
Preliminary Plat Approval Date: _____
Date and period of previous preliminary plat extensions: _____
Proposed time extension length: _____
<b>2. Subdivider information</b>
Name: _____
Address: _____
Telephone: _____
Signature: _____ Date _____
<b>3. Describe the requested extension, addressing the following points</b> (Attach additional pages as needed):
<ul style="list-style-type: none"><li>a. Progress made in complying with the conditions of preliminary plat approval;</li><li>b. Circumstances which have affected the timing of the subdivision development;</li><li>c. The extent to which any significant changes in the area have occurred or are expected to occur during the time of the extension period; and</li><li>d. Whether or not the provision of public facilities and services in the area will be disrupted by the requested extensions.</li></ul>
<b>OFFICE USE ONLY</b>
Extension Request Received on ____ / ____ / ____ by _____
Fee paid on ____ / ____ / ____
Materials deemed complete on ____ / ____ / ____ by _____
Site inspected on ____ / ____ / ____ by _____
Notice of Planner's recommendation and review by Commissioners sent to subdivider on ____ / ____ / ____ by _____
Scheduled for review at County Commission meeting at _____ on ____ / ____ / ____

# APPENDIX 18: FINAL PLAT APPLICATION FORM

## Applicant Information

Landowner(s)

Name:

Address:

Telephone:

E-mail:

Landowner(s) Signature and Date:

Landowner(s) Representative:

Name:

Address:

Telephone:

E-mail:

Representative Signature and Date:

## Subdivision Information

**Name of Preliminary Plat:**

**Location:** (     1/4) Section                      Township                      Range

**Date of Preliminary Plat Approval:**

**Descriptive Data:**

\_\_\_\_\_ Total area (of final plat) in acres:

\_\_\_\_\_ Total acreage in lots/spaces/units:

\_\_\_\_\_ Total number of lots/spaces/units:

\_\_\_\_\_ Maximum size of lots:

\_\_\_\_\_ Minimum size of lots:

\_\_\_\_\_ Total acreage in parks, open space, and/or common facilities:

\_\_\_\_\_ Total acreage in separate road parcels:

<b>Land Use(s)</b> Indicate the number of lots or spaces in each category.
Residential, single family
Residential, multi-family: <i>Indicate types of multi-family structures and number of each, e.g., duplex, four-plex</i>
Mobile Home Park
Recreational Vehicle Park
Condominiums or townhouses: <i>Indicate types of structures and number of each.</i>
Planned unit development: <i>Indicate types of structures and number of each (e.g., single-family homes, multiple family structures, commercial buildings).</i>
Commercial
Industrial
Other (please describe):

<b>Final Plat Submittal Package</b>	
_____	Final Plat (or plan) enclosed.
_____	Final Plat Supplements enclosed.
_____	Final Plat checklist enclosed.
_____	Final Plat review fee(s) enclosed.

# APPENDIX 19: FINAL PLAT CHECKLIST

## Section A: Completed by Subdivider

Name of Preliminary Plat:

Location:

Property Owner:

Legal Description:

Property Geocode/Parcel ID:

Date of Completion by Subdivider:

Subdivider Explanatory Comments:

Section B: Completed by Planning Department			
	Date:	By:	Comment:
Application Received			
Clerk & Recorder Review			
Examining Land Surveyor Review (if applicable)			
Legal Review			
BCC Review Date			
Date Mylar Needed			

**Section C: Completed by Subdivider and Planner/Subdivision Administrator**

Items and Information, Filled Out by: (Note if Not Applicable)	Subdivider	Planner/Subdivision Administrator	
		Incomplete	OK/NA
Final Plat Application Form			
Final Plat Review Fee			
<b><i>Final Plat or Plan</i></b>			
Submitted in accordance with the Montana Uniform Standards for Final Subdivision Plats			
a. One blueline/hard copy (legal size)			
b. Digital copy			
c. One (1) signed/notarized mylar plat (AFTER application is determined to be complete)			
<b><i>Face of the Final Plat (or Plan) shall include:</i></b>			
d. Vicinity map			
e. Approved land uses (e.g., agricultural, residential, commercial, industrial, mixed use)			
When required by the conditions of subdivision approval:			
1. Water bodies			
2. Floodplain			
3. Construction setback from watercourses			
4. Site-specific building envelopes			
5. No-build areas			
6. Ground elevations			
7. Other (as required by conditions of subdivision approval).			
<b><i>Final Plat/Plan Supplements:</i></b>			
a. Certificate of a title abstractor (title company)			
b. Covenants (plat approval covenants and/or owner association covenants) or deed restrictions relating to the subdivision			
c. Certificate from the Montana Department of Environmental Quality or Madison County Sanitarian			
d. Subdivider's certificate indicating which public improvements have been installed			
e. Subdivision improvements agreement and financial guaranty (bond, letter of credit, escrow agreement)			
As applicable:			
f. Articles of incorporation and bylaws for any property owners association being created at the time of final plat approval.			
g. Certification by County sanitarian that plans and			

Items and Information, Filled Out by: (Note if Not Applicable)	Subdivider	Planner/Subdivision Administrator	
		Incomplete	OK/NA
specifications for sanitary facilities (sewer, water, stormwater, and solid waste) have been approved.			
h. County road Encroachment Permit(s)			
i. Right to Farm and Emergency Services Declarations			
j. Letter of preliminary plat approval			
k. Written consent of any conservation easement holder			
l. Copy of any easement or document confirming legal access to the subdivision			
m. Articles of incorporation and bylaws for any property owners association for the subdivision (ORIGINAL required if association is created at time of subdivision)			
n. Copy of county road encroachment permits recorded with the clerk and recorder.			
o. Copy of any pertinent water-related permits (e.g., floodplain development permit from county, stormwater discharge permit from DEQ, 404 permit from U.S. Army corps of Engineers, and/or 310 permit from local conservation district)			
p. Copy of approved Weed Management Plan			

County Comments:

# APPENDIX 20: MODEL SUBDIVISION IMPROVEMENTS AGREEMENT

---

## MODEL SUBDIVISION IMPROVEMENTS AGREEMENT

The parties to this Subdivision Improvements Agreement ("this agreement") are \_\_\_\_\_ ("the subdivider") and \_\_\_\_\_ ("the County").

WHEREAS, the subdivider desires to defer construction of improvements described in Attachment B;

WHEREAS, the purpose of this Agreement is to protect the County and is not intended for the benefit of contractors, suppliers, laborers or others providing work, services, or materials to the Subdivision, or for the benefit of lot or home buyers in the Subdivision; and

WHEREAS, the mutual promises, covenants and obligations contained in this Agreement are authorized by state law and the County subdivision regulations.

NOW THEREFORE BE IT RESOLVED, The Parties hereby agree as follows:

1. Effective Date: The effective date of this Agreement shall be the date that final subdivision plat approval is granted by the County.
2. Attachments: The Attachments cited herein are hereby made a part of this Agreement.

### Subdivider's Obligations

3. Improvements: The Subdivider shall construct and install, at his own expense, those subdivision improvements listed in Attachment B of this Agreement. The Subdivider's obligation to complete the improvements shall arise upon approval of the final subdivision plat, shall not be conditioned on the commencement of construction in the development or sale of any lots or improvements within the subdivision, and shall be independent of any obligations of the County contained in this Agreement.
4. Security: To secure the performance of his obligations under this Agreement, the Subdivider shall deposit with the County on or before the effective date, an Irrevocable Letter of Credit (or other financial security acceptable to the local officials) in the amount of \$\_\_\_\_\_. The letter of credit shall be issued by \_\_\_\_\_ (lending institution), be payable at sight to the County and bear an expiration date not sooner than 4 years after the effective date of this Agreement. The letter of credit shall be payable to the County at any time upon presentation of (1) a sight draft drawn on the issuing lending institution in the amount up to \$\_\_\_\_\_, (2) a signed statement or affidavit executed by an authorized County official stating that the Subdivider is in default under this Agreement; and (3) the original copy of the letter of credit.
5. Standards: The Subdivider shall construct the required improvements according to the standards and specifications required by the County as specified in Attachment D of this agreement.

6. Warranty: The Subdivider warrants that each and every improvement shall be free from defects for a period of 1 year from the date that the County accepts the dedication of the last improvement completed by the Subdivider.
7. Commencement and Completion Periods: The Subdivider shall complete all of the required improvements within 1 year from the effective date of this Agreement.
8. Compliance with Law: The Subdivider shall comply with all relevant laws, ordinances, regulations and requirements in effect at the time of subdivision plat approval when meeting his obligations under this Agreement.

#### County's Obligations

9. Inspection and Certification:
  - a. The County shall provide for inspection of the improvements as they are completed and, where found acceptable, shall certify those improvements as complying with the standards and specifications set forth in Attachment D of this Agreement. The inspection and certification, shall occur within 14 days of notice by the Subdivider that the improvements are complete and he desires County inspection and certification. Before requesting County certification of any improvement the Subdivider shall present to the County valid lien waivers from all persons providing materials or performing work on the improvement.
  - b. Certification by the County does not constitute a waiver by the County of the right to draw funds under the letter of credit in the event defects in or failure of any improvement are found following the certification.
10. Notice of Defect: The County shall provide timely notice to the Subdivider whenever inspection reveals that an improvement does not conform to the standards and specifications set forth in Attachment D, or is otherwise defective. The Subdivider shall have 30 days from the date the notice is issued to remedy the defect. The County may not declare a default under this Agreement during the 30 day remedy period unless the Subdivider clearly indicates he does not intend to correct the defect. The Subdivider shall have no right to correct the defect in, or failure of, any improvement found after the County accepts dedication of the improvements.
11. Reduction of Security: After the acceptance of any improvement, the amount that the County is entitled to draw on the letter of credit shall be reduced by an amount equal to 90 percent of the estimated cost of the improvement as shown in Attachment B. At the request of the Subdivider, the County shall execute a certificate verifying the acceptance of the improvement and waiving its right to draw on the letter of credit to the extent of the amount. Upon the certification of all of the improvements the balance that may be drawn under the credit shall be available to the County for the one year warranty period plus an additional 90 days.
12. Use of Proceeds: The County shall use funds drawn under the letter of credit only for the purposes of completing the improvements or correcting defects in or failure of the improvements.

#### Other Provisions

13. Events of Default: The following conditions, occurrences or actions shall constitute a default by the Subdivider during the completion period:

- a. failure to complete construction of the improvements within 1 year of final subdivision plat approval;
  - b. failure to remedy the defective construction of any improvement within the remedy period;
  - c. insolvency of the Subdivider or the filing of a petition for bankruptcy;
  - d. foreclosure of the property or assignment or conveyance of the property in lieu of foreclosure.
14. Measure of Damages: The measure of damages for breach of this Agreement shall be the reasonable cost of completing the improvements. For purposes of this Agreement the estimated cost of the improvements as specified in Attachment B shall be prima facie evidence of the minimum cost of completion. However, neither that amount nor the amount of the letter of credit establishes the maximum amount of the Subdivider's liability. The County shall be entitled to complete all unfinished improvements at the time of default regardless of the extent to which development has taken place in the Subdivision or whether development ever was commenced.
15. Local Government Rights Upon Default:
- a. Upon the occurrence of any event of default, the County may draw on the letter of credit to the extent of the face amount of the credit less the estimated cost (as shown in Attachment B) of all improvements previously certified by the County. The County shall have the right to complete improvements itself or contract with a third party for completion, or the County may assign the proceeds of the letter of credit to a subsequent Subdivider who has acquired the Subdivision and who shall have the same rights of completion as the County if and only if the subsequent Subdivider agrees in writing to complete the unfinished improvements.
  - b. In addition, the County may suspend final plat approval during which time the Subdivider shall have no right to sell, transfer or otherwise convey lots or homes within the Subdivision without the express approval of the County or until the improvements are completed and certified by the County.
16. Indemnification: The Subdivider agrees to indemnify and hold the County harmless for and against all claims, costs and liability of every kind and nature, for injury or damage received or sustained by any person or entity in connection with, or on account of the performance of work under this Agreement. The Subdivider is not an employee or agent of the County.
17. Amendment or Modification: The Parties to this Agreement may amend or modify this Agreement only by written instrument executed on behalf of the County and by the Subdivider.
18. Attorney's Fees: Should either party be required to resort to litigation, arbitration or mediation to enforce the terms of this agreement, the prevailing party, whether plaintiff or defendant, shall be entitled to costs, including reasonable attorney's fees and expert witness fees, from the opposing party. If the court, arbitrator or mediator awards relief to both parties, each shall bear its own costs in their entirety.
19. Third Party Rights: No person or entity who is not party to this Agreement shall have any right of action under this Agreement, except that if the County does not exercise its rights within 60 days following an event of default, a purchaser of a lot or home in the Subdivision may bring an action in mandamus to compel the County to exercise its rights.

20. Scope: The Agreement constitutes the entire agreement between the parties and no statement, promise or inducement that is not contained in this Agreement shall be binding on the parties.
21. Time: For the purpose of computing the commencement and completion periods, and time periods for County actions, times in which war, civil disasters, acts of God or extreme weather conditions occur shall not be included if the events prevent the Subdivider or the County from performing the obligations under this Agreement.
22. Assigns: The benefits of this Agreement to the Subdivider may not be assigned without the express written approval of the County. Such approval may not be withheld unreasonable, but any unapproved assignment is void. There is no prohibition on the right of the County to assign its rights under this Agreement.

The County shall release the original Subdivider's letter of credit if it accepts new security from any Subdivider or lender who obtains the property. However, no action by the County shall constitute a release of the original Subdivider from his liability under this Agreement.

23. Severability: If any part, term or provision of this Agreement is held by the courts to be illegal the illegality shall not affect the validity of any other part, term or provision, and the rights of the parties shall be construed as if the part, term or provision were never part of the Agreement.

Dated this \_\_\_\_ day of \_\_\_\_\_, 20\_\_\_\_.

\_\_\_\_\_  
County Official

\_\_\_\_\_  
Subdivider

## **ACCEPTABLE FORMS OF IMPROVEMENTS GUARANTEES**

The following are acceptable means of guaranteeing subdivision improvements agreements, although others may also be acceptable. The irrevocable letter of credit is often the preferable guaranty because it is usually feasible for a subdivider to secure, and the local government can readily obtain funds to complete the required improvements should the subdivider default on installing the improvements. A suggested irrevocable letter of credit and commentary are included as part of this Appendix. The other common guaranties are also explained below.

The subdivider shall provide one or more of the following financial security guarantees in the amount of 125% of the engineer's estimated total cost of installing all required improvements.

### **1. Letter of Credit**

Subject to governing body approval, the subdivider shall provide the governing body an irrevocable letter of credit from a bank or other reputable institution or individual certifying the following:

- a. That the creditor guarantees funds in the amount approved by the governing body.
- b. That if the subdivider fails to complete the specified improvements within the required period, the creditor will immediately pay to the governing body upon presentation of a sight draft without further actions, an amount of cash necessary to finance the completion of those improvements, up to the limit of credit state in the letter.
- c. That this letter of credit may not be withdrawn, or reduced in amount, until released by the governing body.

### **2. Escrow Account**

The subdivider shall deposit cash, or collateral readily convertible to cash at face value, either with the governing body or in escrow with a bank. The use of collateral other than cash, and the selection of the bank where funds are to be deposited must be approved by the governing body.

Where an escrow account is to be used, the subdivider shall give the governing body an agreement with the bank guaranteeing the following:

- a. That the funds in the escrow account are to be held in trust until released by the governing body and may not be used or pledged by the subdivider as security for any obligation during that period.
- b. That, should the subdivider fail to complete the required improvements, the bank shall immediately make the funds in escrow available to the governing body for completing these improvements.

### **3. Surety Performance Bond**

The bond shall be executed by a surety company authorized to do business in the State of Montana and acceptable as a surety to the governing body and countersigned by a Montana agent. The bond shall be payable to the County of Madison. The bond shall be in effect until the completed improvements are accepted by the governing body

**MODEL  
IRREVOCABLE LETTER OF CREDIT**

Letter of Credit No. [ \_\_\_\_\_ ]

[Name of Local Government]

[Date]

[Address]

Gentlemen:

We hereby establish in your favor our Irrevocable Letter of Credit # \_\_\_\_\_ for the account of \_\_\_\_\_ (Subdivider) \_\_\_\_\_, available by your drafts at sight up to an aggregate amount of \$ \_\_\_\_\_. Should \_\_\_\_\_ (Subdivider) \_\_\_\_\_ default or fail to complete the improvements under the terms specified in the attached subdivision improvements agreement for \_\_\_\_\_ (name of subdivision) \_\_\_\_\_ we shall pay on demand your sight draft or drafts for such funds, to the limit of credit set forth herein; as are required to complete said improvements.

All drafts must be presented prior to \_\_\_\_\_ expiration date \_\_\_\_\_ and this Letter of Credit must accompany the final draft for payment. Drafts drawn hereunder must be by sight draft marked:

\*Drawn under \_\_\_\_\_ (lending institution) \_\_\_\_\_, Letter of Credit # \_\_\_\_\_ dated \_\_\_\_\_ (date of Letter of Credit) \_\_\_\_\_, \* and the amount drawn endorsed on the reverse hereof by the lending institution.

Unless otherwise state, this Letter of Credit is Subject to the Uniform Customs and Practices for Commercial Documentary Credits (1983 Revision) International Chamber of Commerce. We hereby agree with the drawers, endorsers and bona fide holders of the drafts drawn under and in compliance with the terms of this Credit that these drafts shall be duly honored upon presentation to the drawee.

This letter of credit may not be withdrawn or reduced in any amount prior to its expiration date except by your draft or written release.

\_\_\_\_\_  
(Lending Institution)

\_\_\_\_\_  
(Signature and Title of Official)

# APPENDIX 21: AMENDED PLAT APPLICATION CHECKLIST

## Section A: Completed by Subdivider

Amended Plat Title:

Location:

Property Owner Name &  
Address:

Engineer/Surveyor & Address:

Legal Description:

Property Geocode/Parcel ID:

Type of Amended Plat:                     Subdivision Exemption (FT, BLA, AL, AE, etc)  
     Platted Building Envelope  
     Material Change to Platted Subdivision  
     Other (explain in comments)

Subdivider Comments:

## Section B: Completed by Planner/Subdivision Administrator

	Date:	By:	Comment:
Application Received			
Exemption Review Board Review			
Clerk & Recorder Review			
Examining Land Surveyor Review (if applicable)			
Legal Review			
BCC Review Date			
Date Mylar Needed			

**Section C: Completed by Subdivider and Planner/Subdivision Administrator**

Items and Information, Filled Out by: (Note if Not Applicable)	Subdivider	Planner/Subdivision Administrator	
		Incomplete	OK/NA
Amended Plat Review Fee			
<b>Amended Plat or Plan</b>			
Submitted in accordance with the Montana Uniform Standards			
a. One blueline/hard copy (legal size)			
b. Digital copy			
c. One (1) signed/notarized mylar plat (AFTER preliminary review complete).			
<b>Face of the Amended Plat (or Plan) shall include:</b>			
a. Vicinity map			
b. Commissioner signature block			
c. Applicable sanitation exemption statements			
d. Recording/filing requirements, as noted during Exemption Review			
<b>Amended Plat/Plan Supplements – If Applicable</b>			
a. Deed(s)			
b. Covenants (plat approval covenants and/or owner association covenants) or deed restrictions relating to the subdivision or subject parcels.			
c. Water and sanitation permitting			

Additional Comments:

# APPENDIX 22: SUBDIVISION EXEMPTION CLAIM APPLICATION

The subdivision exemption request will be examined pursuant to MCA 76-3-201 and 76-3-207 and the Madison County Subdivision Regulations.

Note to Applicant: The purpose of this review is to enable Madison County to determine whether or not the proposed use of an exemption from local subdivision review would evade the Montana Subdivision and Platting Act. You will be notified of the Exemption Review Board's decision within 20 working days of submittal of a **complete** application to the Madison County Clerk and Recorder's Office. A complete application consists of the review fee and 3 copies of the request for exemption review, certificate of survey (as required) and supporting documents.

<b>1. Landowner</b> <i>(if more than two landowners, please attach additional sheets)</i>	
Name	E-mail:
Address	Phone
Name	E-mail:
Address	Phone
<b>2. Surveyor</b>	
Name	Firm
Address	Phone
<b>3. Existing Parcel(s)</b> <i>(if more than two parcels, please attach additional sheets)</i>	
A. Location _____ Section _____, Township _____ Range _____	
Other Legal Description:	
Geocode # 25- _____ <div style="display: flex; justify-content: space-around; width: 100%; font-size: small;"> <span>(2)</span> <span>(4)</span> <span>(2)</span> <span>(1)</span> <span>(2)</span> <span>(2)</span> <span>(4)</span> </div>	
When was the parcel created <i>(example: Occasional Sale COS 999, 5/1/92)?</i>	
Has a subdivision application for the parcel been withdrawn or denied?    ___ Yes    ___ No	
B. Location _____ Section _____, Township _____ Range _____	
Other Legal Description:	
Geocode # 25- _____ <div style="display: flex; justify-content: space-around; width: 100%; font-size: small;"> <span>(2)</span> <span>(4)</span> <span>(2)</span> <span>(1)</span> <span>(2)</span> <span>(2)</span> <span>(4)</span> </div>	
When was the parcel created <i>(example: Occasional Sale COS 999, 5/1/92)?</i>	
Has a subdivision application for the parcel been withdrawn or denied?    ___ Yes    ___ No	

--

**4. Type of Exemption and Reason or Justification**

**Gift or Sale to Immediate Family Member ("Family Transfer")**

Recipient(s)	Relationship to Claimant	Age

- Attach copies of all deeds, contracts, restrictions and covenants related to this property recorded within the past year.
- If recipients are under age 18, attach documentation of trust, custodianship pursuant to the Montana Uniform Transfers to Minors Act., etc.

Date Landowner(s) became sole owner(s) of parcel to be divided.

**Agricultural Exemption**

Description of current and proposed agricultural use:

Explanation of eligibility under 15.7.202, MCA:

**Relocation of Common Boundary Lines Outside or Adjoining a Platted Subdivision**

Describe and provide documentation showing the need or reason for the relocation:  
(attach supporting documentation)

**Lot Aggregation/Relocation of Common Boundary Lines within Platted Subdivision**

Describe and provide documentation showing the need or reason for the relocation:  
(attach supporting documentation)

<input type="checkbox"/> <b>Security for Construction ("Mortgage Exemption")</b>
Attach signed and notarized statement from lending institution confirming that the exempt parcel is necessary to secure a construction loan for buildings or other improvements on the parcel or for refinancing.
<input type="checkbox"/> <b>Other</b>
Reason/justification:
<b>5. Intentions for Use</b>
Claimants' and recipients' intentions for the use of each parcel (including existing, new and remainder parcels) ( <i>i.e. will the parcel(s) be used for agriculture, residences, etc.?</i> ):
<b>6. Intentions for Disposition</b>
Claimants' and recipients' long term and short term intentions for the disposition of each parcel (including existing, new and remainder parcels) ( <i>i.e. after this transaction is finalized, will the parcel(s) be retained by recipient, sold, gifted, etc.?</i> ):
<b>7. Attachments</b>
Certificate of Survey
Certificate of Exemption, signed and notarized
Copies of recorded deeds documenting present ownership for all affected parcels.
Copies of draft deeds for exchange of ownership, if any exchange is proposed.
Copies of draft deed restrictions or covenants, if any.
Copies of all related certificates of survey filed after January 1, 2003.
Documentation supporting the proposed exemption.
(Family Transfer) Copies of all deeds, contracts, restrictions and covenants related to this property recorded within the past year.
(Family Transfer) If recipients are under age 18, documentation of trust, custodianship pursuant to the Montana Uniform Transfers to Minors Act, etc.
(Mortgage Exemption) Statement from lending institution confirming need.
(Ag Exemption) Draft deed(s) for transferring property or copy of agreement to buy and sell.

**8. Acknowledgements** (initialed by all landowners)

I (we) understand that the State of Montana provides that certain divisions of land, which would otherwise constitute subdivisions, are exempt from local subdivision review and approval, unless the transactions are an attempt to evade the Montana Subdivision and Platting Act.

**Landowner Initials:** \_\_\_\_\_

I (we) affirm that this exemption claim is not an attempt to evade the Montana Subdivision and Platting Act.

**Landowner Initials:** \_\_\_\_\_

**I (we) recognize** that I may be subject to penalty if my actions are deemed to be an effort to evade subdivision review, as set forth in the Montana Code Annotated:

- 76-3-301(3): If transfers not in accordance with this chapter [i.e., Chapter 3, Local Regulation of Subdivisions] are made, the county attorney shall commence action to enjoin further sales or transfers and compel compliance with all provisions of this chapter. The cost of such action shall be imposed against the party not prevailing.
- Violations: Except as provided in 76-3-207, any person who violates any provision of the Montana Subdivision and Platting Act or any local regulations adopted pursuant thereto shall be guilty of a misdemeanor and punishable by a fine of not less than \$100 or ore than \$500 or by imprisonment in a county jail for not more than three (3) months or by both fine and imprisonment. Each sale, lease, or transfer of each separate parcel of land in violation of any provision of this chapter or any local regulation adopted pursuant thereto must be deemed a separate and distinct offense.

**Landowner Initials:** \_\_\_\_\_

**I (we) recognize** that making false statements on this form could subject me to criminal prosecution for False Swearing (MCA 45-7-202) and Perjury (MCA 45-7-201).

**Landowner Initials:** \_\_\_\_\_

**I (we) recognize** that pursuant to MCA 45-7-203(1), Unsworn falsification to authorities, a person commits an offense under MCA 45-7-203 if, with the purpose to mislead a public servant in performing an official function, the person:

- i. makes any written false statement that the person does not believe to be true;
- ii. purposely creates a false impression in a written application for any pecuniary or other benefit by omitting information necessary to prevent statements from being misleading;
- iii. submits or invites reliance on any writing that the person knows to e forged, altered, or otherwise lacking in authenticity; or
- iv. submits or invites reliance on any sample, specimen, map, boundary mark, or other object that the person knows to be false.

**Landowner Initials:** \_\_\_\_\_

**I (we) understand** that if the Exemption Review Board determines that y (our) request is an attempt to evade the Montana Subdivision and Platting Act, then I (we) have the right to appeal that decision to the governing body according to the Madison County Subdivision Regulations.

**Landowner Initials:** \_\_\_\_\_

## 9. Affidavit (required from all landowners)

\_\_\_\_\_, Landowner(s),  
being first duly sworn upon oath, deposes and says as follows:

I (we), as Claimant(s), have read the foregoing Subdivision Exemption Claim Application and affirm that it is true and correct.

\_\_\_\_\_ Date \_\_\_\_\_  
*Landowner's Signature*

\_\_\_\_\_ Date \_\_\_\_\_  
*Landowner's Signature*

State of \_\_\_\_\_

County of \_\_\_\_\_

Subscribed and sworn to before me on this \_\_\_\_\_ day of \_\_\_\_\_, 20\_\_\_\_.

(seal)

Notary Public for the State of \_\_\_\_\_

Residing at \_\_\_\_\_

My commission expires \_\_\_\_\_

XX

**Below are examples of certification required on the face of the survey:  
\*Acknowledgement, date, signature, and notarization is required for all exemption certifications**

XX

**Certificate of Exemption  
(Family Gift or Sale)**

I (We) hereby certify that the purpose of this division of land is to transfer Tract \_\_\_\_\_ as shown on this certificate of survey to (name of grantee), my (father/mother/daughter/son/wife/husband). I certify that this the single/only gift or sale I have made to the aforementioned immediate family member in Madison County for the purpose of this exemption. Furthermore, I certify that I am entitled to use this exemption and I am in compliance with all conditions imposed by law and regulation on this use of this exemption. Therefore, this division of land is exempt from review as a subdivision pursuant to section 76-3-207(1)(b), MCA.

XX

**Certificate of Exemption  
(For Agricultural Purposes)**

I (We) certify that the purpose of this survey is to create a parcel of land to be used exclusively for agricultural purposes, and that a covenant has been entered into by the parties to the transaction, running with the land and revocable only by mutual consent of the governing body and the property owner that will require subdivision review of the parcel, that the land will be used exclusively for agricultural purposes, and this survey is, therefore, exempt from review as a subdivision pursuant to section 76-3-207(1)(c), MCA.

XX

**Example Acceptance of Certificate of Survey – Agricultural Covenant Exemption**

This declaration, made this \_\_\_ day of \_\_\_\_\_, 20\_\_\_, by (Name of Property Owner(s)), hereinafter referred to as the "Declarant(s);

That whereas, Declarant is the owner of certain property described as tract(s) \_\_\_\_\_, Certificate of Survey number \_\_\_\_\_ on file and record in the office of the Clerk and Recorder of Madison County, Montana.

Now, therefore, Declarant hereby declares that the parcel(s) described above shall be held, sold, and conveyed in any matter subject to the following covenant, which shall run with the real property and be binding on all parties having any right, title or interest in the described property (properties) or any part thereof, their heirs, executors, successors, administrators, and assignees, and shall bind each

owner thereof. This covenant may be revoked by the governing body after receiving final subdivision approval. The governing body is deemed to be party to and may enforce this covenant.

The parcel(s) described above shall be used exclusively for agricultural purposes and no building, house, dwelling, or structure requiring sanitary restrictions imposed under Title 76, Chapter 4.

XX

**Certificate of Exemption  
(Relocation of Common Boundary)**

I (We) certify that the purpose of this survey is to relocate a common boundary line between adjoining properties outside of a platted subdivision (or inside a platted subdivision / between a single lot within a platted subdivision and adjoining land outside a platted subdivision) and that no additional parcels are hereby created. Therefore, this survey is exempt from review as a subdivision 76-3-207(1)(a), (d), or (e) MCA.

XX

**Certificate of Exemption  
(Aggregation of Lots)**

I (We) certify that the purpose of this survey is to aggregate existing lots within a within a platted subdivision, that fewer than six lots are affected, and that no additional parcels are hereby created. Therefore, this survey is exempt from review as a subdivision pursuant to section 76-3-207(1)(f) MCA.

XX

**Certificate of Exemption  
(SECURITY FOR MORTGAGE, LIEN, OR TRUST INDENTURE)**

I (We) hereby certify that the purpose of this survey is to create a parcel of land to provide security for mortgage or loan purposes and that this exemption complies with all conditions imposed on its use, Therefore, this survey is exempt from review as a subdivision pursuant to Section 76-3-201 (1)(b) MCA.

XX

**Certificate of Exemption  
(Rights-of-Way or Utility Site)**

I (We) certify that the purpose of this survey is to create a parcel for a \_\_\_\_\_ utility site and therefore this survey is exempt from review as a subdivision pursuant to section 76-3-201(1)(h) MCA. Furthermore, I (We) certify that a change in the use of land to residential, commercial, or industrial is subject to the requirements of subdivision review.

XX

**Certificate of Exemption  
Approval by Governing Body**

The County Commission of Madison County, Montana, hereby certifies that the Commission has examined the \_\_\_\_\_ (INSERT TYPE OF EXEMPTION USED) \_\_\_\_\_ Certificate of Survey and found it to be exempt from subdivision review.

XX

**Certificate of County Treasurer**

I hereby certify, pursuant to Section 76-3-207(3), MCA, that all real property taxes assessed and levied on the land shown hereon have been paid.

# APPENDIX 23: MODEL AGRICULTURAL COVENANT REMOVAL

---

COMES NOW \_\_\_\_\_, owners of the following described real property, hereinafter called Owners, and the County Commission of Madison County, Montana, hereinafter called Governing Body.

WHEREAS the Owners are the record title holders of Tract \_\_\_\_\_ of Certificate of Survey No. \_\_\_\_\_, filed as Document No. \_\_\_\_\_ in the office of the Clerk and Recorder of Madison County, Montana; and

WHEREAS Tract \_\_\_\_\_ of Certificate of Survey No. \_\_\_\_\_ is situated in the \_\_\_\_\_ (1/4, 1/2) of Section \_\_\_\_\_, Township \_\_\_\_\_, Range \_\_\_\_\_, P.M.M., Madison County, Montana; and

WHEREAS, said Certificate of Survey contains the following Agricultural Covenant:

[Insert covenant from Certificate of Survey]; and

WHEREAS, said Certificate of Survey and Agricultural Covenant is signed by the Owners herein or the predecessors in interests; and

WHEREAS the Owners and Governing Body now wish to remove the Agricultural Exemption Covenant for the purpose of changing the use of said property after the Tract has gone through subdivision review [as the Tract has been aggregated back into the original tract of record] [as the Tract has been for the use of a public or governmental entity and has been through a public hearing and the determination made to remove the Agricultural Covenant].

NOW, THEREFORE, the parties herein agree that the Covenant to use Tract \_\_\_\_\_ in Certificate of Survey \_\_\_\_\_ exclusively for agricultural purposes is hereby revoked and the following conditions are imposed on the Tract:

1. [final plat for the review of the Tract as a subdivision must be completed].
2. [the Tract must be used exclusively by a governmental or public entity for the following purposes \_\_\_\_\_].

DATED this \_\_\_\_ day of \_\_\_\_\_, 20\_\_\_\_.

\_\_\_\_\_  
NAME, Owners

\_\_\_\_\_  
NAME, Chair of County Commission for  
Madison County